

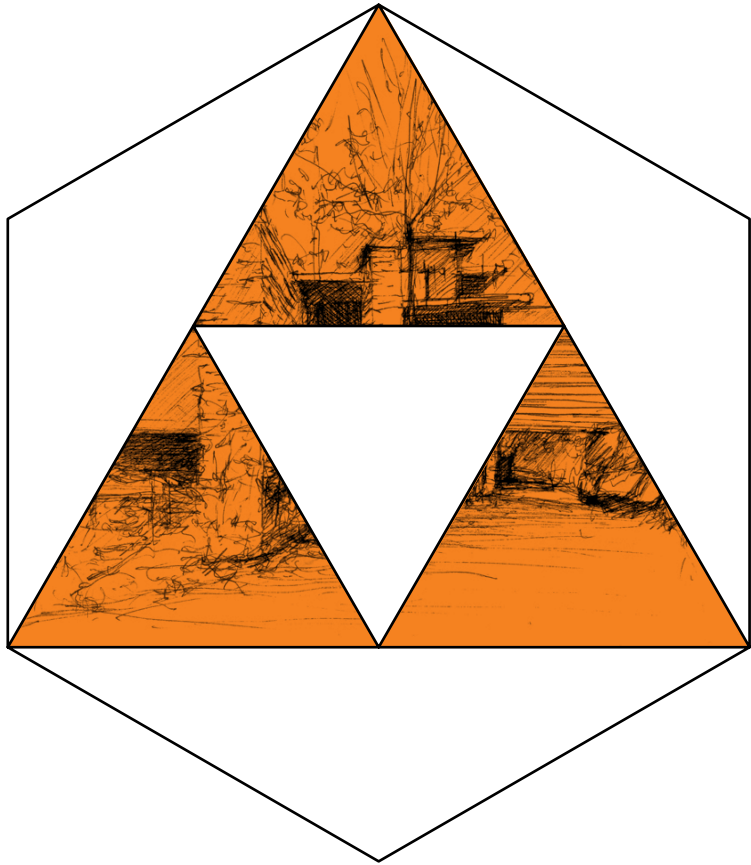

AUTOMATION CATALOGUE





**06 HOW TO CHOOSE THE RIGHT AUTOMATION**

**SLIDING GATE OPERATOR**

- 12 Hercules
- 14 Achilles 1200 - 2200
- 16 Achilles 4000

**SWING GATE OPERATOR**

- 20 Hermes 200
- 22 Hermes 250
- 24 Ulixes 350
- 26 Ulixes 500
- 28 Alpheo
- 30 Zefiro 180
- 32 Zefiro 350

**SECTIONAL AND OVERHEAD DOORS**

- 36 Icarus 1000

**TUBULAR AND ROLLING SHUTTERS MOTORS**

- 40 Ares
- 42 Win

**ROAD BARRIERS**

- 46 Daphne 3m fast
- 48 Daphne 4m
- 50 Daphne 6m

**KITS**

- 54 Hercules Kit
- 55 Hermes Kit
- 56 Ulixes 350 Kit
- 57 Alpheo Kit
- 58 Zefiro 180 Kit
- 59 Daphne Kit

**ACCESSORIES**

- 64 Energy
- 65 Signal accessories
- 70 Safety and security devices
- 72 Access and control accessories
- 74 Racks
- 76 Other useful information
- 77 General condition of sale
- 78 How to reach us



## STAGNOLI A WAY OF BEING

Stagnoli was established in Desenzano del Garda in 1980. "Ideas in motion" is our slogan, a slogan that perfectly sums up our philosophy.

Over the years, Stagnoli has managed to combine tradition and innovation. We are a company with a significant growth rate, and are highly customer-orientated.

Thanks to a very long-standing experience in the field and to our constant investment in research, the company has now an established range of products for the automation of gates and entrances of any kind.

Each Stagnoli automation system has been designed and implemented to make the daily lives of people easier, and "ideas in motion" means just that.

The reliability of the products, the accurate design, and research that always puts the customer's needs first, has enabled Stagnoli to be known all over the world and to be a truly international company.

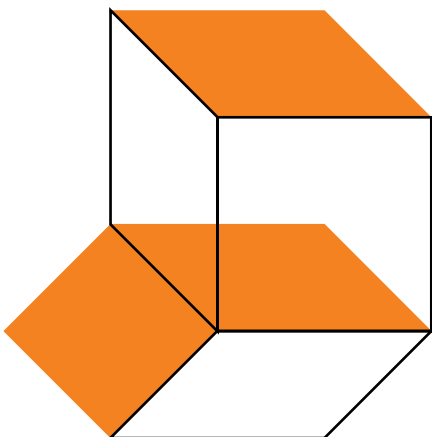



## DESIGN AND TECHNOLOGY

---

From the beginning Stagnoli has laid the strategic foundations of its development on the quality, functionality, convenience, and durability of its products in terms of both materials and design.

These two aspects of our project have been instrumental in the creation of Stagnoli products; from the highest quality plastics, to cast aluminium, all materials used in Stagnoli products have undergone extensive tests durability and reliability.

The design of Stagnoli products is the result of a vision of a product which is geared towards combining innovation, technology, and performance, and a line that enhances the features of our automated systems, in terms of durability, practicality, and attractive design. Stagnoli produces all transmission gears in house, using the high-performance thermoplastic material (glass fibre reinforced PA6) used in their automated systems, thanks to a thirty years' experience in the manufacture of plastic gears.



## HOW TO CHOOSE THE RIGHT PRODUCT

---



## FOR SLIDING GATES

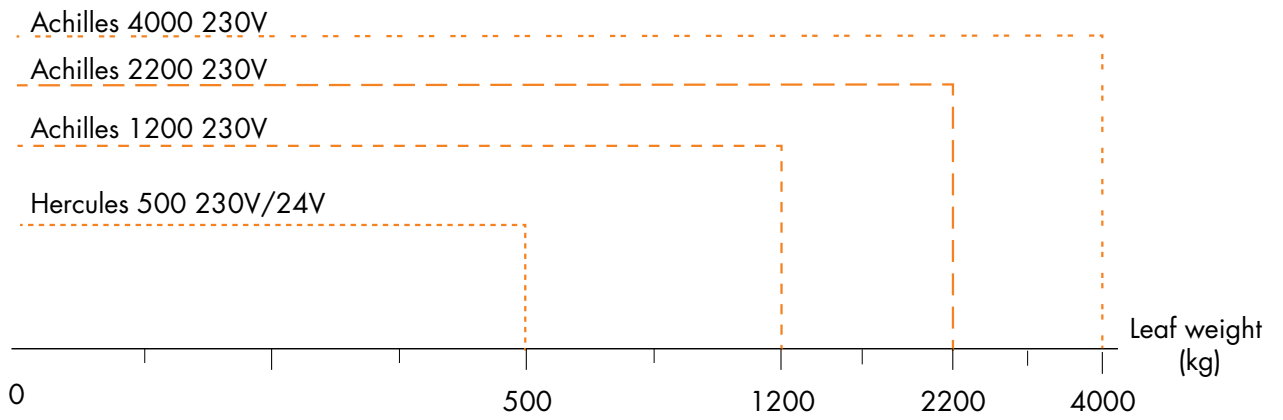

For sliding gate automations it's necessary to pay attention to the weight of the leaf.

## FOR SWING GATES

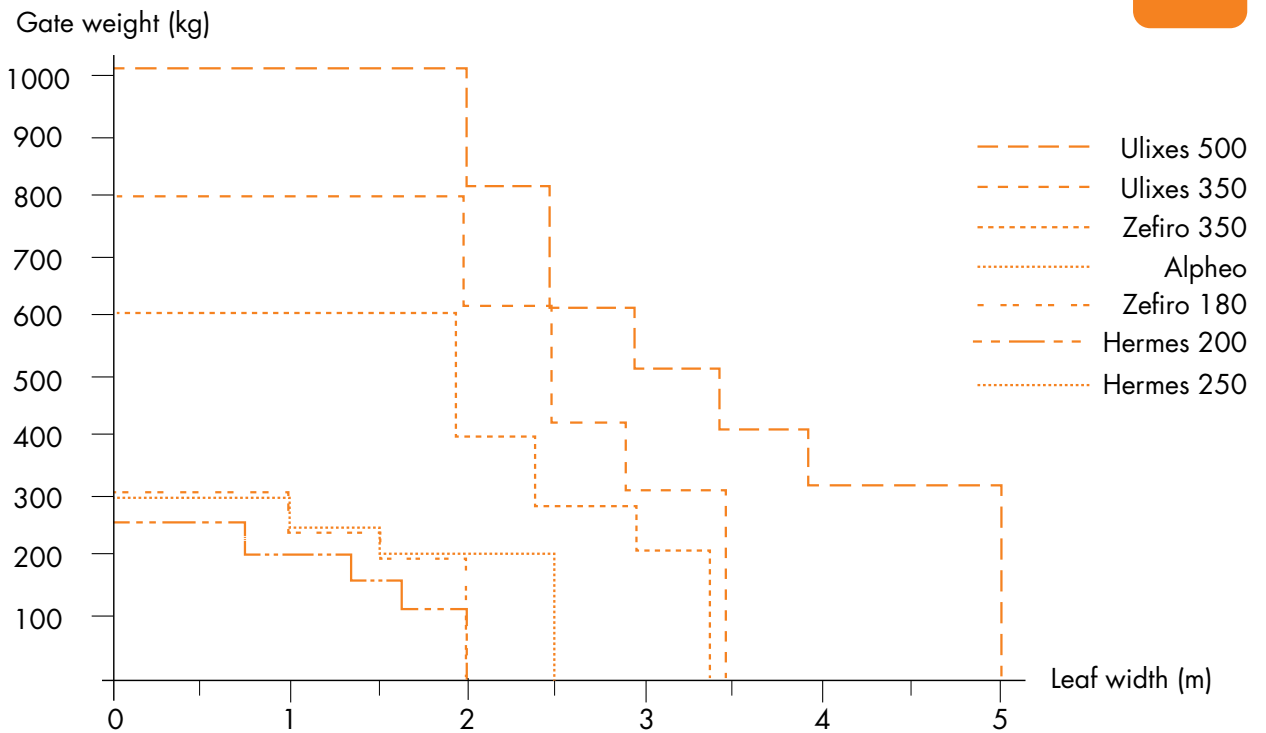

For swing gate automations, pay attention to weight and width of each single leaf.

## FOR SECTIONAL AND ONE-PIECE OVERHEAD GARAGE DOORS



Max thrust force (N)

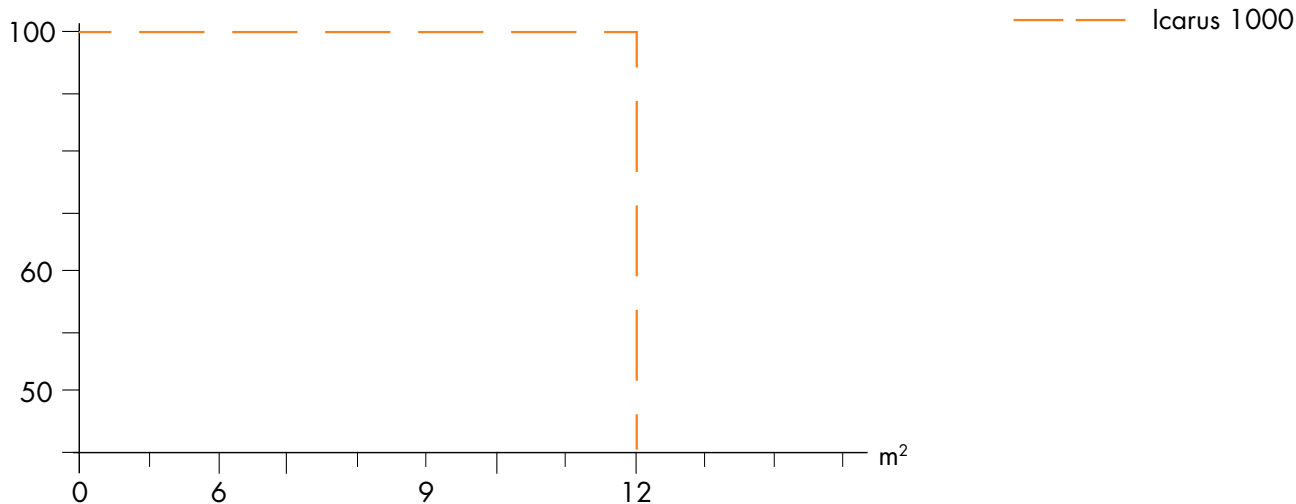

For sectional and one-piece overhead garage doors pay attention to dimension of surface and to the weight of the door.

## FOR ROLLING SHUTTERS



Torque (Nm)

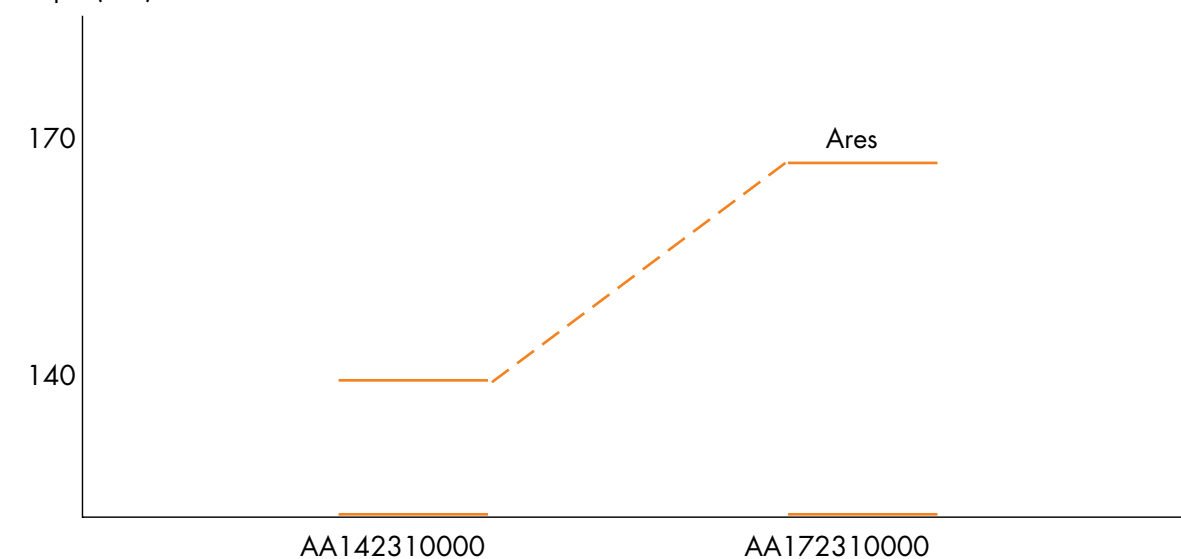



## FOR TUBULAR MOTORS

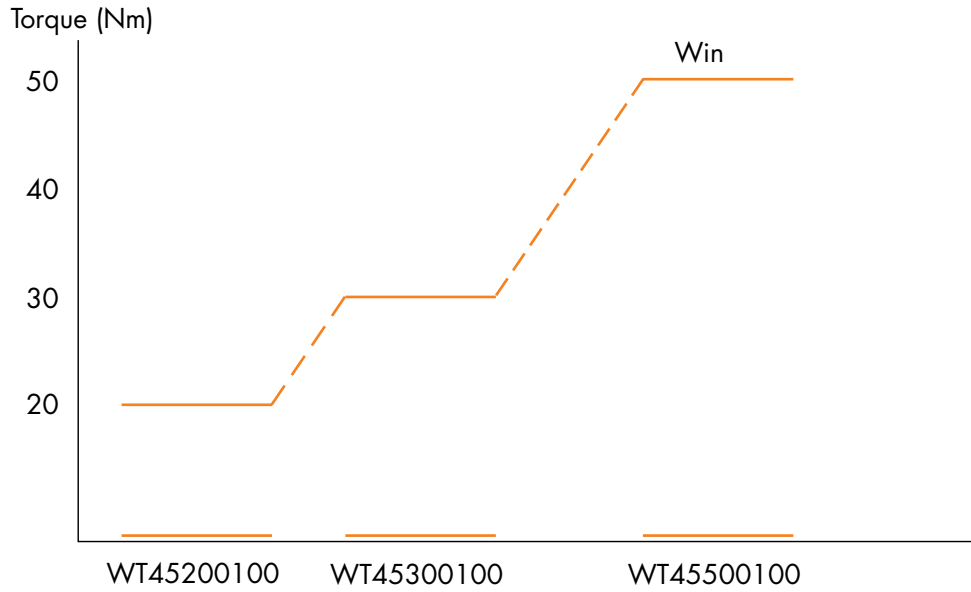

## FOR AUTOMATIC BARRIERS

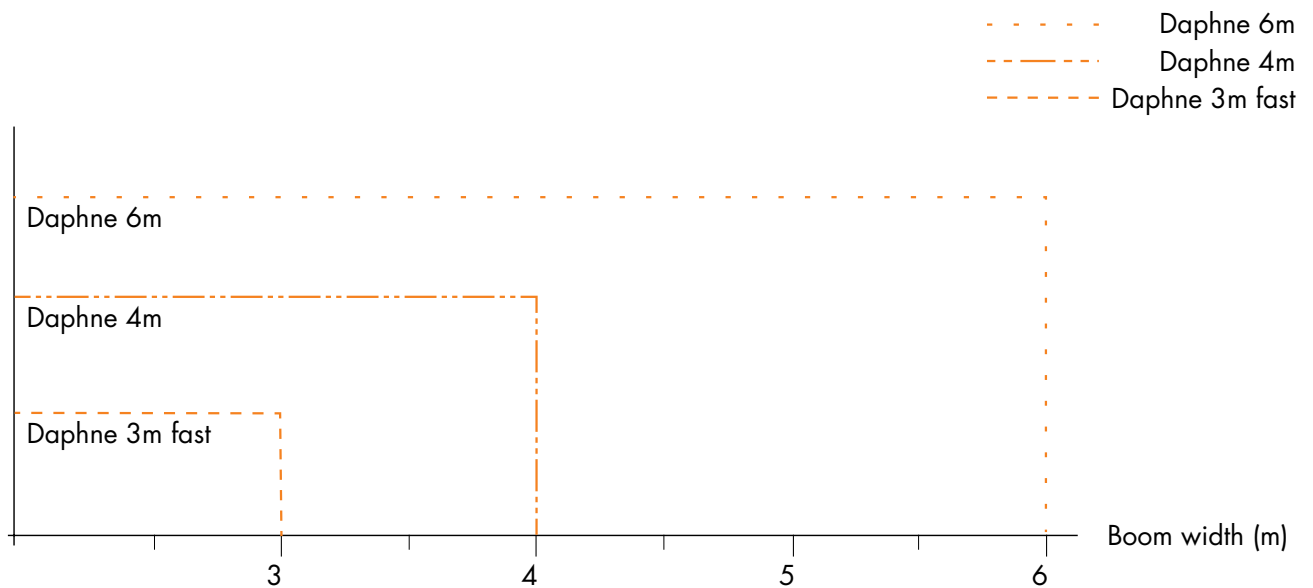



## SLIDING GATE OPERATOR

---

HERCULES



# HERCULES

The Hercules sliding gate operator (max 500Kg) is available in 230Vac and 24Vdc versions.

The proper operation of the sliding gate opener is guaranteed for long time thanks to the sturdy materials used for its production.

The frontal manual release lever allows the user to manually handle the gate in case of emergency.



## TECHNICAL DATA

### HERCULES 230Vac

### HERCULES 24Vdc

|                                  |          |           |
|----------------------------------|----------|-----------|
| Power supply (Vac/50Hz)          | 230      | 230       |
| Motor power supply               | 230Vac ~ | 24Vdc === |
| Max absorption (A)               | 1,5      | 9         |
| Max motor power (W)              | 340      | 220       |
| Working temperature (°C)         | -20<>+55 | -20<>+55  |
| Thermal overload protection (°C) | 150      | -         |
| Duty cycle (%)                   | 30       | 70        |
| IP protection level              | 43       | 43        |
| Max thrust force (N)             | 650      | 450       |
| Max gate weight (Kg)             | 500      | 500       |
| Torque (Nm)                      | 24,5     | 15        |
| Max speed (m/min)                | 11       | 11        |
| Weight (Kg)                      | 12       | 12        |

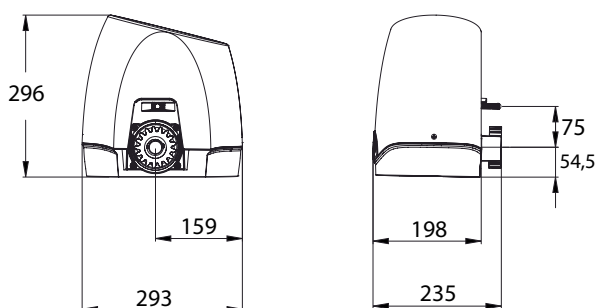



## IRREVERSIBLE ELECTROMECHANICAL GEARMOTOR FOR SLIDING GATES MAX 500 KG

### SH502302100

Hercules 230Vac motor power supply, complete with base plate and save energy control board with built-in receiver.

### SH500241000

Hercules for intensive use 24Vdc motor, complete with encoder, base plate and save energy control board with built-in receiver.

## ACCESSORIES



### H230

Control board for Hercules motor 230Vac with built-in receiver.



### A24

Control board (for 24 V motors) with integrated receiver for fixed or rolling code remote controls.



### AA016

Battery charger kit for 24Vdc motor. Suitable for control board.



### AFCM

Magnetic limit switch.

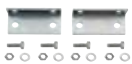

### ATH001

Fixing kit brackets for base plate complete with screws.



### AH001

Hercules base plate.



### CAR

Warning notice (specify the required language).



### RACKS

See Racks pages.

# ACHILLES 1200/2200

The Achilles series sliding gate operators are the perfect choice to automate industrial gates (max 1200/2200kg).

The proper operation of the motor is guaranteed for long time thanks to the sturdy materials used for its production.

Achilles is available in 230Vac version.



| TECHNICAL DATA           | ACHILLES 1200 | ACHILLES 2200 |
|--------------------------|---------------|---------------|
|                          | 230Vac        | 230Vac        |
| Power supply (Vac/50Hz)  | 230           | 230           |
| Max absorption (A)       | 4             | 5,5           |
| Motor power supply       | 230Vac ~      | 230Vac ~      |
| Max motor power (W)      | 550           | 750           |
| Working temperature (°C) | -20<>+55      | -20<>+55      |
| Duty cycle (%)           | 50            | 50            |
| IP protection level      | 44            | 44            |
| Max thrust force (N)     | 1000          | 1600          |
| Max gate weight (Kg)     | 1200          | 2200          |
| Weight (Kg)              | 18            | 18            |

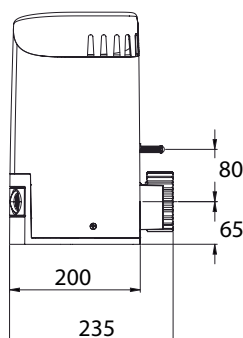
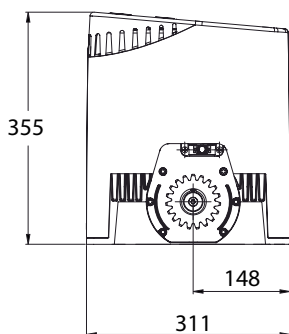

## IRREVERSIBLE ELECTROMECHANICAL GEARMOTOR FOR SLIDING GATES MAX 1200KG OR 2200KG



### **SA12230H230**

Achilles 1200 irreversible gear motor, complete with base plate and control board.  
230Vac single phase gear motor and power supply, with self-ventilation.

### **SA22230H230**

Achilles 2200 irreversible gear motor, complete with base plate and control board.  
230Vac single phase gear motor and power supply, with self-ventilation.

## ACCESSORIES



### **H230**

Control board for Achilles motor 230Vac  
with built-in receiver.



### **AA004**

Protective steel cover for Achilles operators.



### **RACKS**

See racks pages.



### **CAR**

Warning notice  
(specify the required language).



### **AA001**

Achilles 1200/2200 base plate.

# ACHILLES 4000

The Achilles 4000 sliding gate opener is exclusively made of highly resistant components and have been designed for the automation of very heavy sliding gates (max 4000kg). The Achilles sliding gate operators is available in 230Vac and 400Vac versions.



## TECHNICAL DATA

### ACHILLES 4000 230Vac      ACHILLES 4000 400Vac

|                          | 230Vac   | 400Vac   |
|--------------------------|----------|----------|
| Power supply (Vac/50Hz)  | 230      | 400      |
| Max absorption (A)       | 6,4      | 3,75     |
| Motor power supply       | 230Vac ~ | 400Vac ~ |
| Max motor power (W)      | 1500     | 1500     |
| Working temperature (°C) | -20<>+55 | -20<>+55 |
| Duty cycle (%)           | 50       | 50       |
| IP protection level      | 44       | 44       |
| Max thrust force (N)     | 3200     | 3200     |
| Max gate weight (Kg)     | 4000     | 4000     |
| Weight (Kg)              | 59       | 59       |

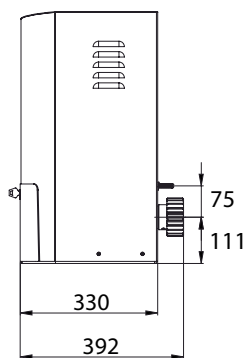
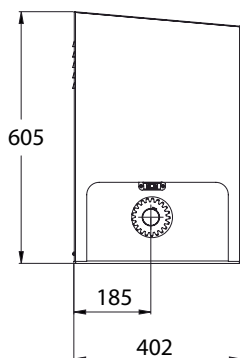



## IRREVERSIBLE ELECTROMECHANICAL GEARMOTOR FOR SLIDING GATES MAX 4000KG



### SA414000000

Achilles 4000 irreversible gearmotor in oil bath for intensive use, with transmission gear M6 and self-ventilation. 230Vac-400Vac power supply. Without control board.

## ACCESSORIES



### SA4041

Control board for Achilles 4000 (230V).



### RACKS

See racks pages.



### CAR

Warning notice  
(specify the required language).



## SWING GATE OPERATOR

---

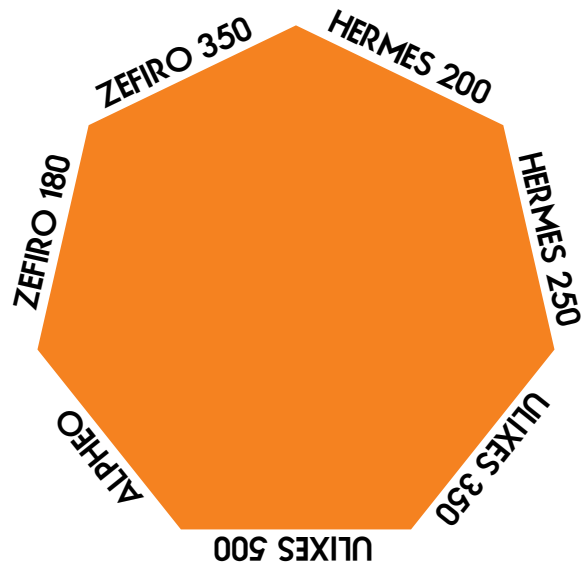

# HERMES 200

The Hermes swing gate operator (max 2 m leaf ) is available in 24Vdc version. Hermes is sturdy and silent, with easy slowdown and patented mechanical stops.



## TECHNICAL DATA HERMES 200

|                          |           |
|--------------------------|-----------|
| Power supply (Vac/50Hz)  | 230       |
| Motor power supply       | 24Vdc === |
| Max absorption (A)       | 4,5       |
| Max motor power (W)      | 110       |
| Working temperature (°C) | -20<>+55  |
| Duty cycle (%)           | 70        |
| IP protection level      | 44        |
| Max thrust force (N)     | 1200      |
| Working time 90°         | 10/15 sec |
| Weight (Kg)              | 3         |

## LIMIT USE

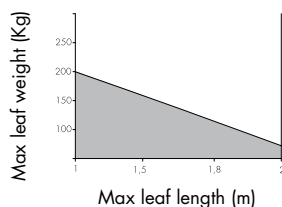

Gate shape, and height and weather conditions, can considerably reduce the values shown above, in the graph.



630 + (325 travel)

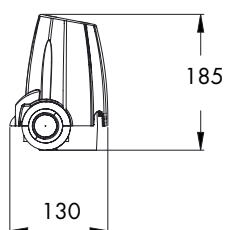
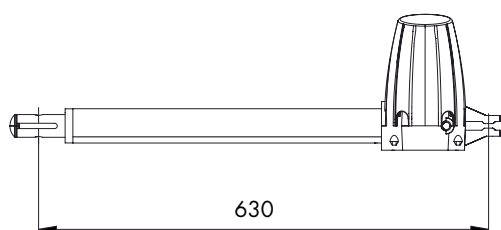



## IRREVERSIBLE ELECTROMECHANICAL GEARMOTOR FOR SWING GATES MAX 2M LEAF

### HEM001

Pair of Hermes electromechanical gear motors (right-hand side and left-hand side) 24Vdc with encoder and fixing brackets, complete of control board (A24ASC31).

## ACCESSORIES



### A24ASC31

Control board in ABS box (18x21) with integrated receiver for fixed or rolling code remote controls (for 24 V motors).



### AA016

Battery charger kit for 24Vdc motor. Suitable for control board.



### Electrolocks

See accessories pages.



### CAR

Warning notice (specify the required language).

# HERMES 250

The Hermes swing gate operator (max 2,5 m leaf ) is available in 24Vdc version.  
Hermes is sturdy and silent, with easy slowdown and patented mechanical stops.



## TECHNICAL DATA HERMES 250

|                          |           |
|--------------------------|-----------|
| Power supply (Vac/50Hz)  | 230       |
| Motor power supply       | 24Vdc === |
| Max absorption (A)       | 4,5       |
| Max motor power (W)      | 110       |
| Working temperature (°C) | -20<>+55  |
| Duty cycle (%)           | 70        |
| IP protection level      | 44        |
| Max thrust force (N)     | 1200      |
| Working time 90°         | 10/15 sec |
| Weight (Kg)              | 4         |

## LIMIT USE

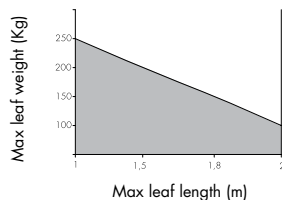

Gate shape, and height and weather conditions, can considerably reduce the values shown above, in the graph.



730 + (420 travel)

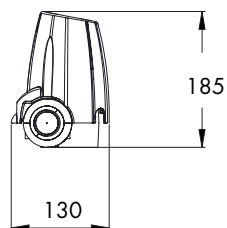
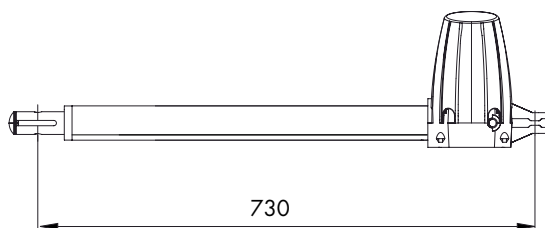



## IRREVERSIBLE ELECTROMECHANICAL GEARMOTOR FOR SWING GATES MAX 2,5M LEAF

### HEM002

Pair of Hermes electromechanical gear motors (right-hand side and left-hand side) 24Vdc with encoder and fixing brackets, complete of control board (A24ASC31).

## ACCESSORIES



### A24ASC31

Control board in ABS box (18x21) with integrated receiver for fixed or rolling code remote controls (for 24 V motors).



### AA016

Battery charger kit for 24Vdc motor. Suitable for control board.



### Electrolocks

See accessories pages.



### CAR

Warning notice (specify the required language).

# ULIXES 350

The Ulixes swing gate operator with 350mm stroke is available in 230Vac and 24Vdc versions.

Thanks to the sturdiness of materials used during production, Ulixes is almost maintenance free and designed to last long.



## TECHNICAL DATA

**ULIXES**  
230Vac

**ULIXES**  
24Vdc

## LIMIT USE

|                                  |          |           |
|----------------------------------|----------|-----------|
| Power supply (Vac/50Hz)          | 230      | 230       |
| Motor power supply               | 230Vac ~ | 24Vdc === |
| Max absorption (A)               | 1,5      | 5         |
| Max motor power (W)              | 340      | 120       |
| Working temperature (°C)         | -20<>+55 | -20<>+55  |
| Thermal overload protection (°C) | 150      | -         |
| Duty cycle (%)                   | 30       | 70        |
| IP protection level              | 44       | 44        |
| Max thrust force (N)             | 500-2000 | 500-2000  |
| Max open angle (°)               | 115      | 115       |
| Working time (sec)               | 15-25    | 15-25     |
| Weight (Kg)                      | 9        | 9         |

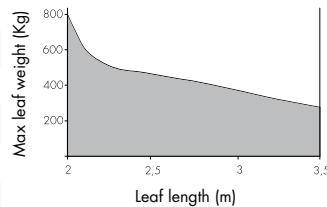

Gate shape, and height and weather conditions, can considerably reduce the values shown above, in the graph.

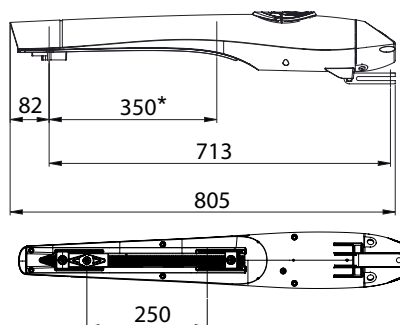
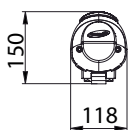
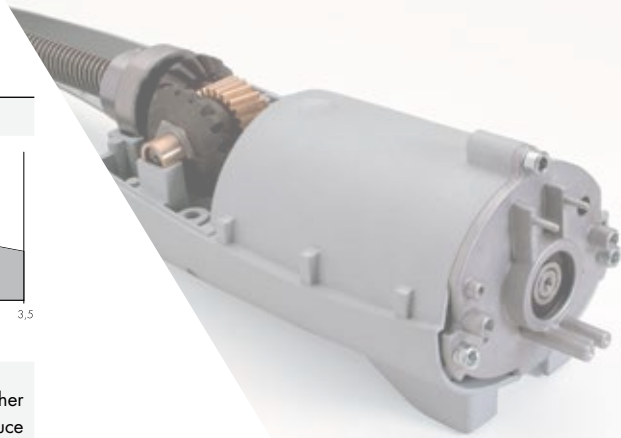



## IRREVERSIBLE ELECTROMECHANICAL GEARMOTOR FOR SWING GATES MAX 3,5M LEAF



### **BU352302002**

Ulixes 350 operator with 230Vac gearmotor and power supply, complete with fixing brackets and mechanical limit switches in opening and closing.

### **BU350242002**

Ulixes 350 operator intensive use with 24Vdc gearmotor, complete with encoder, fixing brackets and mechanical limit switches in opening and closing.

## ACCESSORIES



### **A24ASC31**

Control board in ABS box (18x21) with integrated receiver for fixed or rolling code remote controls (for 24 V motors).



### **U230ASC31**

Control board for 230Vac operators (in ABS box 18x21), with integrated receiver for fixed or rolling code remote controls.



### **AA016**

Battery charger kit for 24Vdc motor. Suitable for control board.



### **Electrolocks**

See accessories pages.



### **CAR**

Warning notice (specify the required language).

# ULIXES 500

The Ulixes swing gate operator with 500mm stroke is available in 230Vac and 24Vdc versions.

Thanks to the sturdiness of materials used during production, Ulixes is almost maintenance free and designed to last long.



## TECHNICAL DATA

**ULIXES**  
230Vac

**ULIXES**  
24Vdc

## LIMIT USE

|                                  |          |           |
|----------------------------------|----------|-----------|
| Power supply (Vac/50Hz)          | 230      | 230       |
| Motor power supply               | 230Vac ~ | 24Vdc === |
| Max absorption (A)               | 1,5      | 5         |
| Max motor power (W)              | 340      | 120       |
| Working temperature (°C)         | -20<>+55 | -20<>+55  |
| Thermal overload protection (°C) | 150      | -         |
| Duty cycle (%)                   | 30       | 70        |
| IP protection level              | 44       | 44        |
| Max thrust force (N)             | 500-2000 | 500-2000  |
| Max open angle (°)               | 115      | 115       |
| Travel time (sec)                | 15-25    | 15-25     |
| Weight (Kg)                      | 10       | 10        |

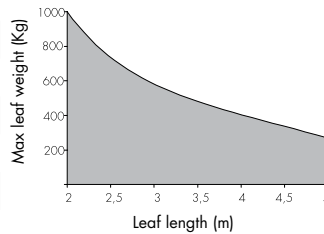

Gate shape, and height and weather conditions, can considerably reduce the values shown above, in the graph.

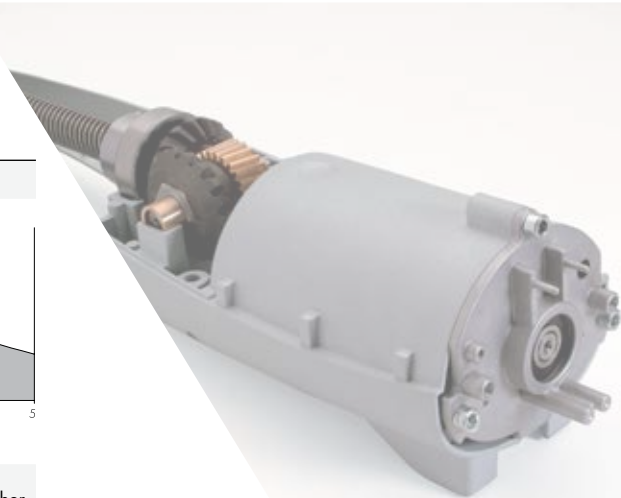
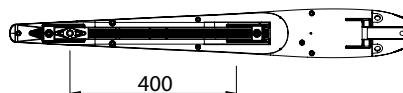
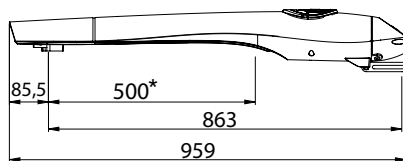
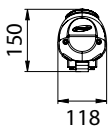

## IRREVERSIBLE ELECTROMECHANICAL GEARMOTOR FOR SWING GATES MAX 5M LEAF



### **BU502302002**

Ulixes 500 operator with 230Vac gearmotor and power supply, complete with fixing brackets and mechanical limit switches in opening and closing phases.

### **BU500242002**

Ulixes 500 operator intensive use with 24Vdc gearmotor, complete with encoder, fixing brackets and mechanical limit switches in opening and closing phases.

## ACCESSORIES



### **A24ASC31**

Control board in ABS box (18x21) with integrated receiver for fixed or rolling code remote controls (for 24 V motors).



### **U230ASC31**

Control board for 230Vac operators (in ABS box 18x21), with integrated receiver for fixed or rolling code remote controls.



### **AA016**

Battery charger kit for 24Vdc motor. Suitable for control board.



### **Electrolocks**

See accessories pages.



### **CAR**

Warning notice (specify the required language).

# ALPHEO

The Alpheo swing gate operator is available in 230Vac and 24Vdc versions. Alpheo series electromechanic articulated swing gate operator, allows to automate swing gates with large pillars. The proper operation of the motor is guaranteed for long time thanks to the sturdy materials used for its production.



## TECHNICAL DATA

**ALPHEO**  
230Vac

**ALPHEO**  
24Vdc

|                                  | 230Vac   | 24Vdc     |
|----------------------------------|----------|-----------|
| Power supply (Vac/50Hz)          | 230      | 230       |
| Motor power supply               | 230Vac ~ | 24Vdc === |
| Max absorption (A)               | 1,3      | 5         |
| Max motor power (W)              | 160      | 120       |
| Working temperature (°C)         | -20<>+55 | -20<>+55  |
| Thermal overload protection (°C) | 150      | -         |
| Duty cycle (%)                   | 30       | 70        |
| IP protection level              | 44       | 44        |
| Max open angle (°)               | 105      | 105       |
| Travel time (sec)                | 16-20    | 16-20     |
| Weight (Kg)                      | 9        | 10        |

## LIMIT USE

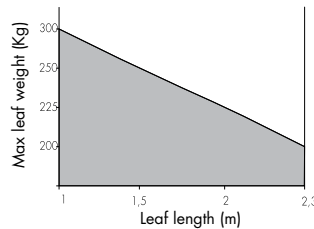

Gate shape, and height and weather conditions, can considerably reduce the values shown above, in the graph.

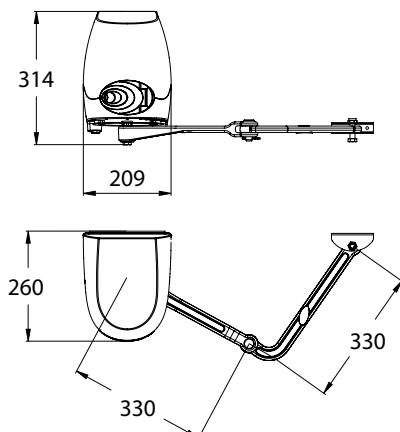

## IRREVERSIBLE ELECTROMECHANICAL GEARMOTOR WITH ARTICULATED ARM FOR SWING GATES MAX 2,3 M LEAF



### **BA232302100**

Alpheo 230Vac with save energy control board and integrated receiver.  
Complete with fixing brackets, articulated arm and mechanical limit switch.

### **BA232300000**

Alpheo 230Vac complete with fixing brackets, articulated arm and mechanical limit switch.

### **BA230241000**

Alpheo 24Vdc with save energy control board , encoder and integrated receiver.  
Complete with fixing brackets, articulated arm and mechanical limit switch.

### **BA230240000**

Alpheo 24Vdc with encoder, fixing brackets, articulated arm and mechanical limit switch.

## ACCESSORIES



### **A24**

Control board (for 24 V motors) with integrated receiver for fixed or rolling code remote controls.



### **AA016**

Battery charger kit for 24Vdc motor.  
Suitable for control board.



### **AGR003**

Telescopic right arm with sliding guide.

### **AGR004**

Telescopic left arm with sliding guide.



### **CAR**

Warning notice  
(specify the required language).



### **U230**

Control boards for Alpheo 230Vac operators with save energy function and fixed or rolling code receiver.



### **AA003**

External release kit for Alpheo operators.



### **Electrolocks**

See accessories pages.

# ZEFIRO 180

The Zefiro underground operator for swing gates is available in 230Vac and 24Vdc versions.

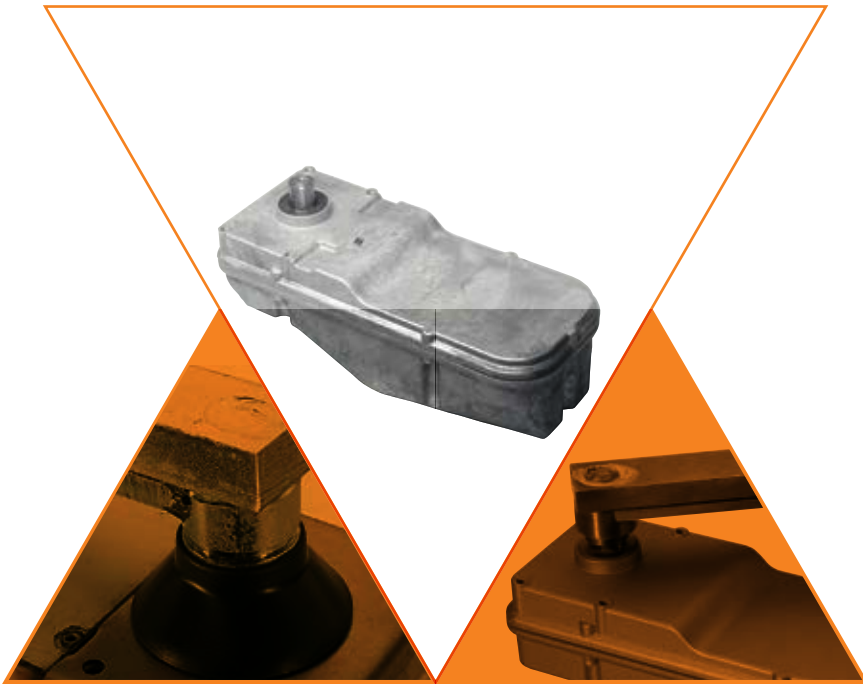

## TECHNICAL DATA

**ZEFIRO**  
230Vac

**ZEFIRO**  
24Vdc

|                                  |            |            |
|----------------------------------|------------|------------|
| Power supply (Vac/50Hz)          | 230        | 230        |
| Motor power supply               | 230Vac ~   | 24Vdc ===  |
| Max absorption (A)               | 1,3        | 7          |
| Max motor power (W)              | 300        | 170        |
| Working time 90°                 | 16 - 20sec | 16 - 20sec |
| Torque (Nm)                      | 300        | 250        |
| Working temperature (°C)         | -20< >+55  | -20< >+55  |
| Thermal overload protection (°C) | 150        | -          |
| Duty cycle (%)                   | 30         | 70         |
| IP protection level              | 67         | 67         |
| Weight (Kg)                      | 9          | 9          |

## LIMIT USE

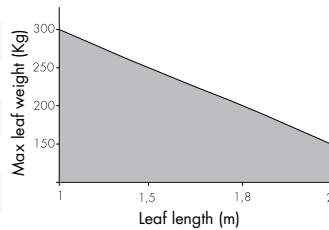

Gate shape, and height and weather conditions, can considerably reduce the values shown above, in the graph.

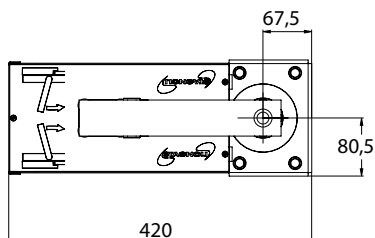
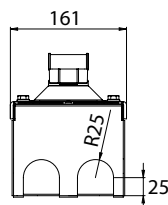
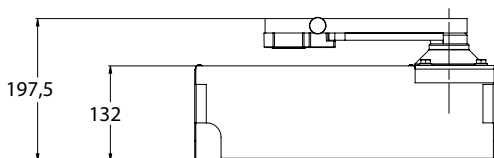
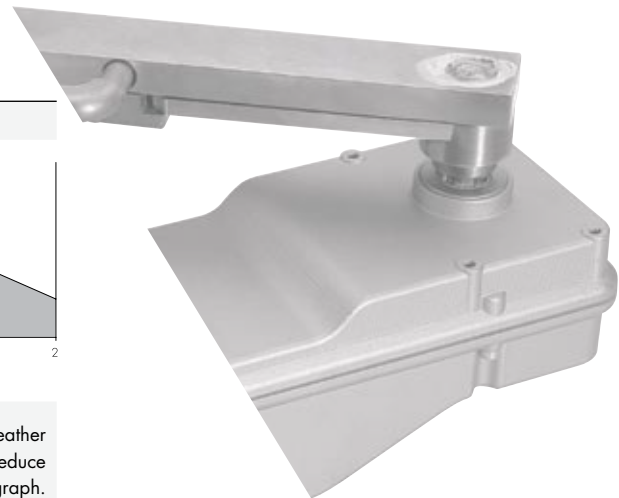

## IRREVERSIBLE ELECTROMECHANICAL UNDERGROUND GEAR MOTOR FOR SWING GATES MAX 2 M LEAF



### **BN182300000**

Zefiro 180, 230Vac gear motor and power supply and IP protection level 67.

### **BN180240000**

Zefiro 180, 24Vdc gear motor for intensive use, with encoder and IP protection level 67.

## ACCESSORIES



### **U230ASC31**

Control board for 230Vac operators (in ABS box 18x21), with integrated receiver for fixed or rolling code remote controls.



### **A24ASC31**

Control board in ABS box (18x21) with integrated receiver for fixed or rolling code remote controls (for 24 V motors).



### **AA016**

Battery charger kit for 24Vdc motor. Suitable for control board.



### **AN010**

Junction adaptor to release the motor from the base of the gate, for an easier installation.



### **AN001**

Zinc-plated foundation case for Zefiro 180, complete with unlocking device and lever.



### **Electrolocks**

See accessories pages.



### **CAR**

Warning notice (specify the required language).

# ZEFIRO 350

The Zefiro underground operator is available in 230Vac and 24Vdc versions.

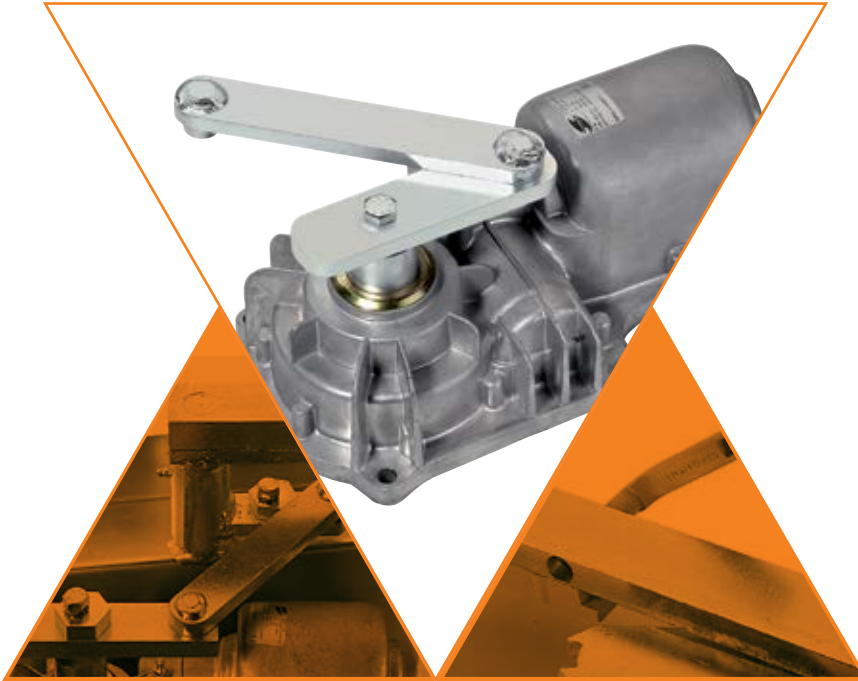

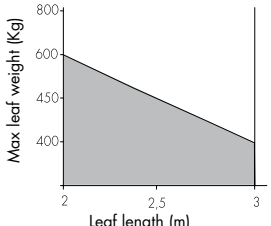
| TECHNICAL DATA                   | ZEFIRO      | ZEFIRO      | LIMIT USE  |
|----------------------------------|-------------|-------------|--|
|                                  | 230Vac      | 24Vdc       |  |
| Power supply (Vac/50Hz)          | 230         | 230         |  <p>Max leaf weight (Kg)</p> <p>Leaf length (m)</p> <p>Gate shape, and height and weather conditions, can considerably reduce the values shown above, in the graph.</p> |
| Motor power supply               | 230Vac ~    | 24Vdc ===   |  |
| Max absorption (A)               | 1,3         | 8           |  |
| Max motor power (W)              | 300         | 190         |  |
| Max open angle (°)               | 360         | 200         |  |
| Working time 90°                 | 16 - 20sec  | 16 - 20sec  |  |
| Torque (Nm)                      | 180         | 180         |  |
| Working temperature (°C)         | -20 < > +60 | -20 < > +60 |  |
| Thermal overload protection (°C) | 150         | -           |  |
| Duty cycle (%)                   | 30          | 70          |  |
| IP protection level              | 67          | 67          |  |
| Weight (Kg)                      | 12          | 12          |  |

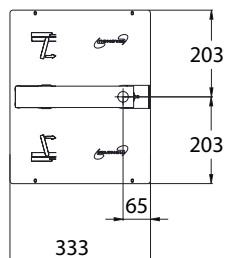
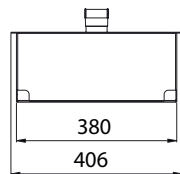
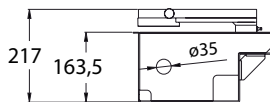



## IRREVERSIBLE ELECTROMECHANICAL UNDERGROUND GEARMOTOR FOR SWING GATES MAX 3 M LEAF



### **BN352300000**

Zefiro 350, 230Vac gearmotor and power supply, IP protection level 67.

### **BN350240000**

Zefiro 350 for intensive use, 24Vdc gearmotor with encoder, IP protection level 67.

## ACCESSORIES



### **A24ASC31**

Control board in ABS box (18x21) with integrated receiver for fixed or rolling code remote controls (for 24 V motors).



### **U230ASC31**

Control board for 230Vac operators (in ABS box 18x21), with integrated receiver for fixed or rolling code remote controls.



### **AN004**

Zinc-plated foundation case for Zefiro 350, complete with unlocking device and lever.



### **AA016**

Battery charger kit for 24Vdc motor. Suitable for control board.



### **AU011**

Mechanical stop for Zefiro 350.



### **AN007**

Opening Kit > 110° for Zefiro 350 electromechanical underground operator.



### **Electrolocks**

See accessories pages.



### **CAR**

Warning notice (specify the required language).



## SECTIONAL AND OVERHEAD DOORS

---

### ICARUS 1000

---



# ICARUS 1000

The Icarus garage door operators for sectional and single-piece overhead doors are available in chain or belt-drive version, with 1000 Newton force.

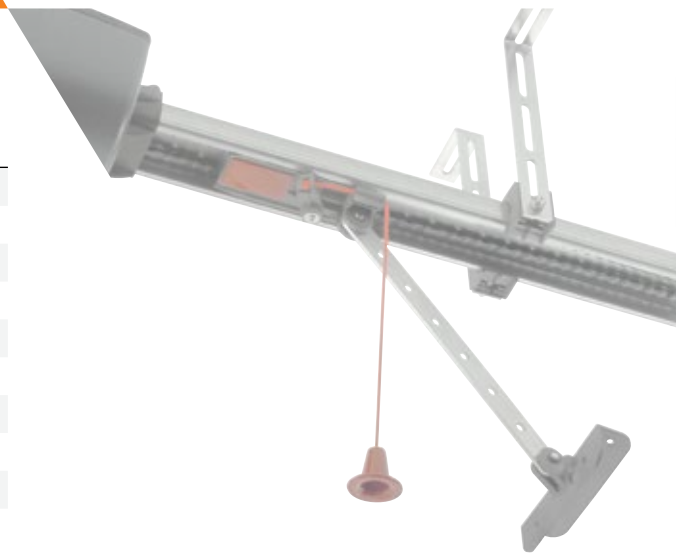

## TECHNICAL DATA

## ICARUS 24Vdc

|                          |                 |
|--------------------------|-----------------|
| Power supply (Vac/50Hz)  | 230             |
| Motor power supply       | 24Vdc ===       |
| Max absorption (A)       | 8               |
| Max motor power (W)      | 200             |
| Working temperature (°C) | -20<->+55       |
| Max thrust force (N)     | 1000            |
| Max speed (m/min)        | 9.3             |
| Duty cycle (%)           | 70              |
| Weight (Kg)              | from 12,8 to 14 |

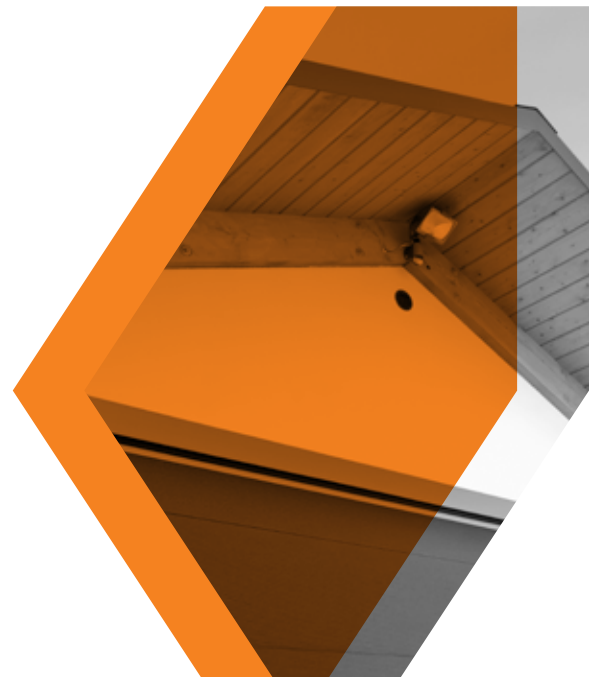
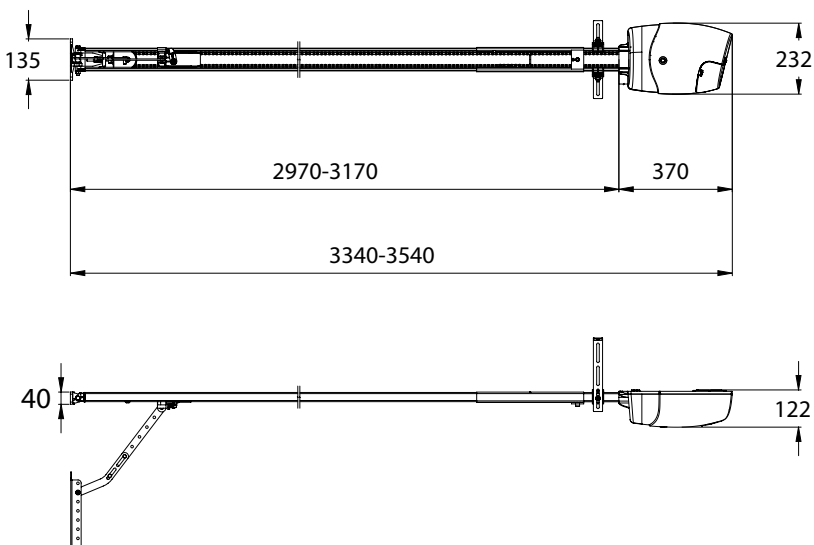



## COMPLETE OPERATOR FOR SECTIONAL AND OVERHEAD DOORS MAX 100KG

### T004823ITR

Icarus 1000N, 24Vdc motor, 2300mm travel, chain-drive and complete with fixing brackets rail, control board with built-in receiver, encoder and courtesy lamp. This article includes two-channel rolling code transmitter.

### T004825ITR

Icarus 1000N, 24Vdc motor, 2500mm travel, chain-drive and complete with fixing brackets rail, control board with built-in receiver, encoder and courtesy lamp. This article includes two-channel rolling code transmitter.

### TCG4823ITR

Icarus 1000N, 24Vdc motor, 2300mm travel, belt-drive and complete with fixing brackets rail, control board with built-in receiver, encoder and courtesy lamp. This article includes two-channel rolling code transmitter.

### TCG4825ITR

Icarus 1000N, 24Vdc motor, 2500mm travel, belt-drive and complete with fixing brackets rail, control board with built-in receiver, encoder and courtesy lamp. This article includes two-channel rolling code transmitter.

## ACCESSORIES



### I24

Control boards for Icarus operators with save energy function, fixed and rolling code receiver.



### AA016

Battery charger kit for 24Vdc motor. Suitable for control board.



### ATKP

Complete rail extension kit 1170mm for chain-drive version only.



### AMOVBAS

Adaptor arm for overhead garage doors with counterweights.

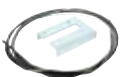

### ASBB

External release for overhead garage doors.



### AI004

Bracket support for chain and belt-drive rails.



### AI005

Adaptor arm extension 600mm for overhead garage doors with counterweights.



### CAR

Warning notice (specify the required language).



TUBULAR MOTORS

---

ROLLING SHUTTERS MOTORS

ARES

WIN



# ARES

Ares electromechanical gear motor for balanced rolling shutters (max 170 Kg) available in 230Vac version.

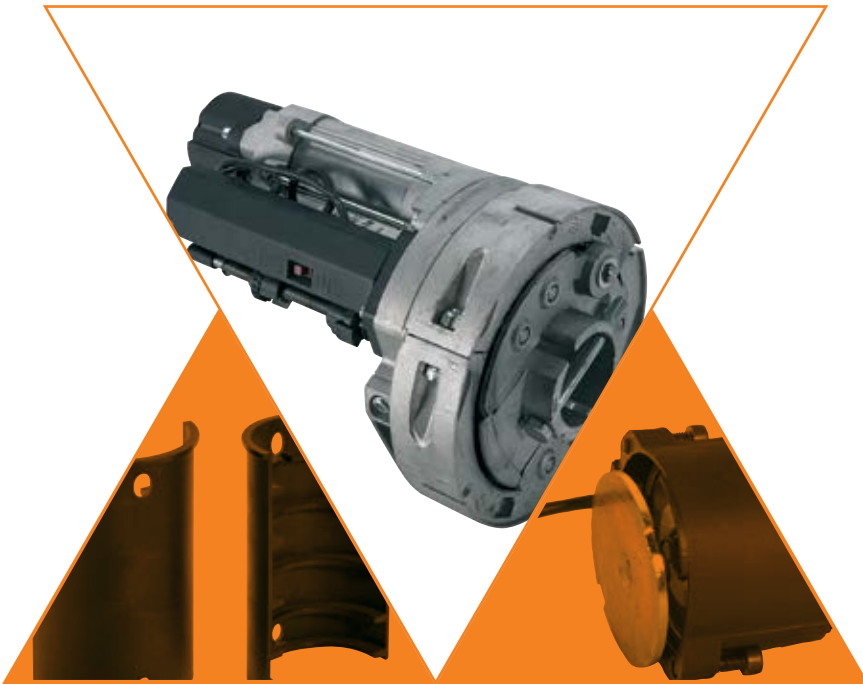

| TECHNICAL DATA                | ARES 60     | ARES 60/S   |
|-------------------------------|-------------|-------------|
| Power supply (Vac/50Hz)       | 230         | 230         |
| Max absorption (A)            | 1,8         | 2,4         |
| Motor power supply            | 230V ~      | 230V ~      |
| Max motor power (W)           | 330         | 450         |
| Working temperature (°C)      | -20 < > +55 | -20 < > +55 |
| Max travel time (Tw)          | 4min        | 4min        |
| Max thrust force (Kg)         | 140         | 170         |
| Torque (Nm)                   | 140         | 190         |
| Rolling shutter diameter (mm) | 60          | 60          |

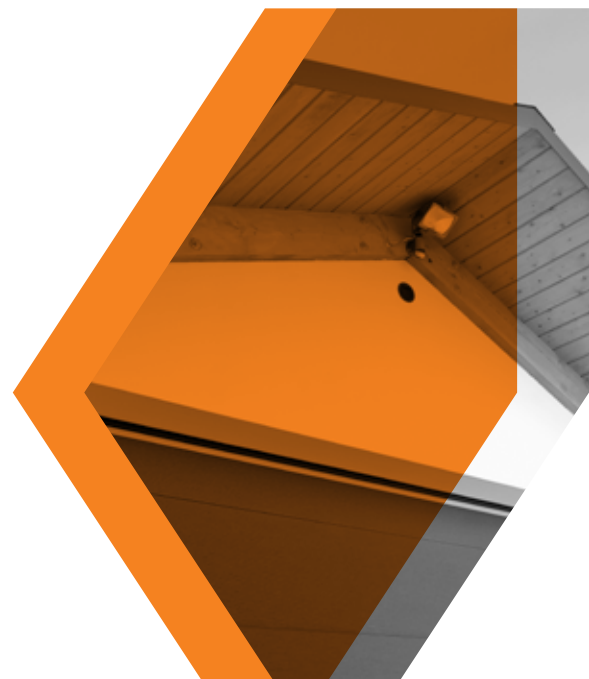



## IRREVERSIBLE ELECTROMECHANICAL GEARMOTOR FOR BALANCED ROLLING SHUTTERS MAX 170KG



### AA142310000

Ares 230Vac gear motor with lifting capacity up to 140Kg, complete with electric brake to get it irreversible.

### AA172310000

Ares 230Vac gear motor with lifting capacity up to 170Kg, complete with electric brake to get it irreversible.

## ACCESSORIES



### AA2041

Control board complete with fixed code receiver for Ares and Win 230Vac motors.



### Push-button

See accessories pages.



### AA006

Shaft reduction 60/42.



### AA007

Shaft reduction 60/48.



### CAR

Warning notice  
(specify the required language).



# WIN

Win tubular motors for rolling shutters and awnings (max 95Kg) is available with limit switch and safety manoeuvre versions.

## TECHNICAL DATA WT 45200100 WT 45300100 WT 45500100

|                          |             |             |             |
|--------------------------|-------------|-------------|-------------|
| Load (Kg)                | 35          | 52          | 95          |
| Rpm                      | 12          | 12          | 12          |
| Torque (Nm)              | 20          | 30          | 50          |
| Power supply (Vac/50Hz)  | 230         | 230         | 230         |
| Max motor power (W)      | 230         | 270         | 300         |
| Max absorption (A)       | 1           | 1,2         | 1,3         |
| Working temperature (°C) | -20 < > +55 | -20 < > +55 | -20 < > +55 |
| External diameter (mm)   | 45          | 45          | 45          |

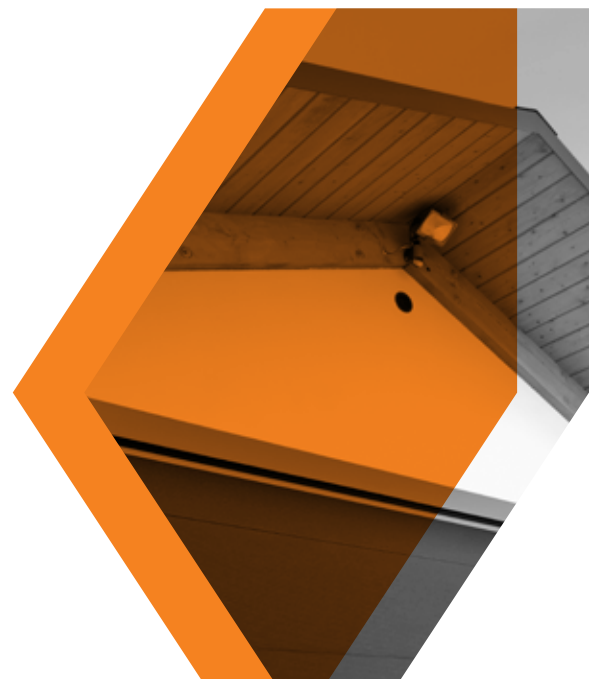

## TUBULAR GEARMOTOR FOR ROLLING-SHUTTERS AND AWNINGS OPENING MAX 95KG



### **WT45200100**

230Vac tubular motor, 20Nm with limit switch.

### **WT45300100**

230Vac tubular motor, 30 Nm with limit switch.

### **WT45500100**

230Vac tubular motor, 50Nm with limit switch.

## ACCESSORIES



### **AA2041**

Control board complete with fixed code receiver for Ares and Win 230Vac motors.



## ROAD BARRIERS

---

DAPHNE 3M FAST



# DAPHNE 3M FAST

The Daphne automatic barrier 3m Fast version 2 sec. is available in 24Vdc version with magnetic encoder and 3m boom. Barrier body is made of zinc painted steel frame and covered by anodized hot painted aluminium panels to grant higher resistance to the atmospherical agents.



## TECHNICAL DATA

## DAPHNE 3M FAST

|                          |           |
|--------------------------|-----------|
| Power supply (Vac/50Hz)  | 230       |
| Motor power supply       | 24Vdc === |
| Max input power (A)      | 6         |
| Max motor power (W)      | 150       |
| Opening time (sec)       | 2         |
| Working temperature (°C) | -20<>+55  |
| Duty cycle (%)           | 90        |
| IP protection level      | 44        |
| Weight (kg)              | 70        |
| Max boom length (m)      | 3         |

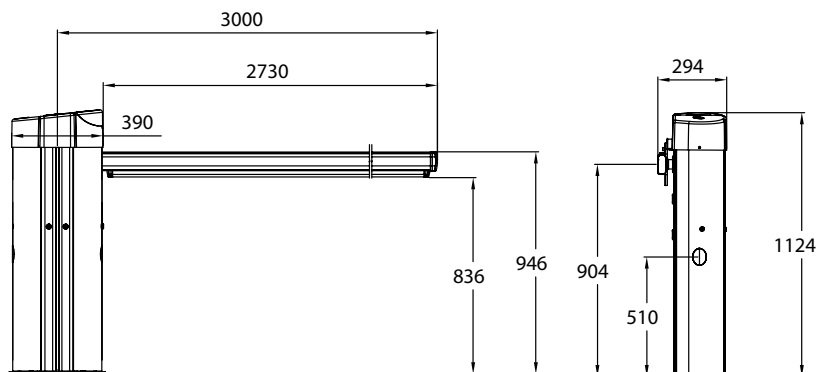

## DAPHNE AUTOMATIC BARRIERS, FAST VERSION 2 SEC. OPEN TIME WITH MAX 3M BOOM



### DA60242000

Daphne barrier body, 24Vdc with foundation ground plate and control board with built-in receiver (rolling and fixed code).  
Complete with built-in flashing light and fixing supports for photocell.  
The barrier can be equipped and personalized with below mentioned accessories.

## ACCESSORIES



**C24**  
24v battery charger control board.



**D24**  
Control board for Daphne barriers.



**DA019**  
3Ah battery fixing kit for Daphne 6m and 3m fast.



**DA021**  
Single channel loop detector.



**DA011**  
Fixed support for boom adjustable height wise.



**AM001**  
Back-up battery (12Vdc - 3Ah).



**DA009**  
Reflecting strips (12 pcs).



**DALED3RV**  
Red and green LED kit for 3M booms.  
**DALED3R**  
Red LED kit for 3M booms.



**DA004**  
3m rectangular boom.



**DA030**  
Calibrated spring for 3m tubular telescopic boom.



**DA023**  
Fixing plate for 3m rectangular boom.

# DAPHNE 4M

The Daphne 4 m automatic barrier is available in 24Vdc version with magnetic encoder and round or rectangular 4m boom. The barrier body is made of zinc painted steel frame and covered by anodized hot painted aluminium panels to grant higher resistance to the atmospherical agents.



## TECHNICAL DATA

## DAPHNE 4M

|                          |           |
|--------------------------|-----------|
| Power supply (Vac/50Hz)  | 230       |
| Motor power supply       | 24Vdc === |
| Max input power (A)      | 6         |
| Max motor power (W)      | 150       |
| Opening time (sec)       | 4         |
| Working temperature (°C) | -20<>+55  |
| Duty cycle (%)           | 90        |
| IP protection level      | 44        |
| Weight (kg)              | 40        |
| Max boom length (m)      | 4         |

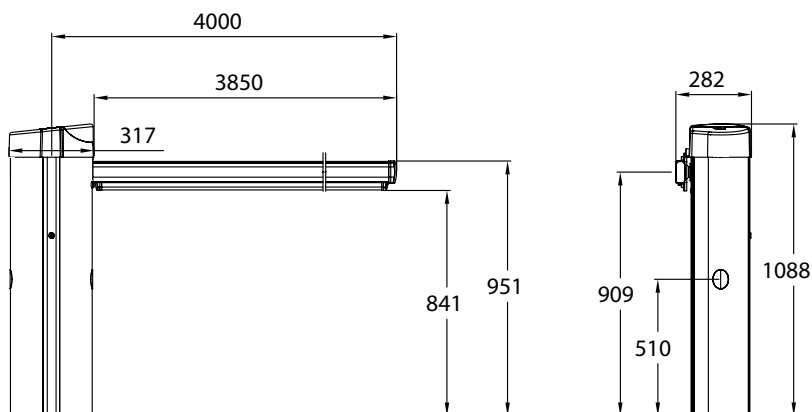



## DAPHNE AUTOMATIC BARRIER WITH ROUND OR RECTANGULAR BOOM MAX 4 M



### DA0241000

Daphne barrier body, 24Vdc with foundation ground plate and control board with built-in receiver (rolling and fixed code).  
Complete with built-in flashing light and fixing supports for photocells.  
The barrier can be equipped and personalized with below mentioned accessories.

## ACCESSORIES



**C24**  
24v battery charger control board.



**D24**  
Control board for Daphne barriers.



**DA015**  
2m modular rack.



**DA021**  
Single channel loop detector.



**DA013**  
3Ah battery fixing kit for Daphne 4m.



**DA025**  
Rectangular boom with 90° joint.



**DA009**  
Reflecting strips (12 pcs).



**AM001**  
Back-up battery (12Vdc - 3Ah).



**DA026**  
Red rubber safe impact profile, complete with caps (length 4m).



**DA011**  
Fixed support for boom adjustable height wise.



**DA005**  
4m tubular boom.  
**DA007**  
Fixing plate for 4m tubular boom.  
**DA029**  
Calibrated spring for 4m tubular boom.



**DA006**  
4m rectangular boom.  
**DA008**  
Fixing plate for 4m rectangular boom.  
**DA024**  
Calibrated spring for 4m rectangular boom.



**DALED4RV**  
Red and green LED kit for 4M booms.  
**DALED4R**  
Red LED kit for 4M booms.

# DAPHNE 6M

The Daphne 6 m automatic barrier is available in 24Vdc version with 6 m telescopic arm for easy transport and installation.

The barrier body is made of zinc painted steel frame and covered by anodized hot painted aluminium panels to grant higher resistance to the atmospherical agents.



## TECHNICAL DATA

## DAPHNE 6M

|                          |           |
|--------------------------|-----------|
| Power supply (Vac/50Hz)  | 230       |
| Motor power supply       | 24Vdc === |
| Max input power (A)      | 6         |
| Max motor power (W)      | 150       |
| Opening time (sec)       | 10        |
| Working temperature (°C) | -20<>+55  |
| Duty cycle (%)           | 80        |
| IP protection level      | 44        |
| Weight (kg)              | 70        |
| Max boom length (m)      | 6         |

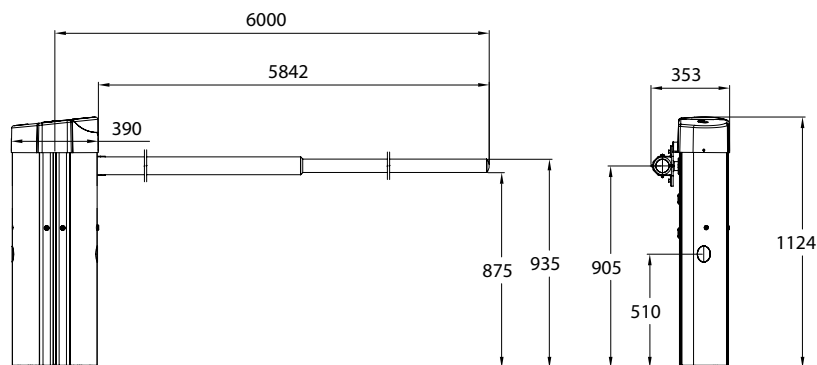
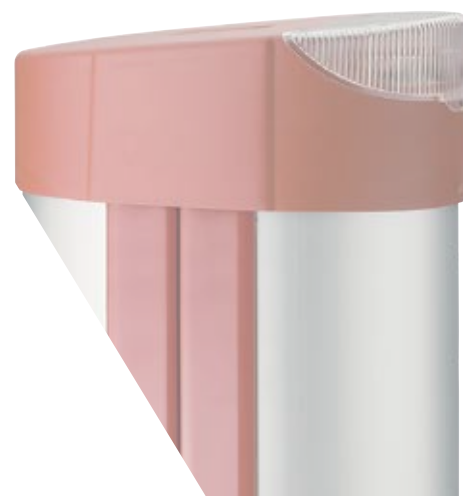



## DAPHNE AUTOMATIC BARRIER WITH TELESCOPIC ARM, MAX 6 M

### DA60241000

Daphne barrier body, 24Vdc with foundation ground plate and control board with built-in receiver (rolling and fixed code).  
Complete with built-in flashing light and fixing supports for photocells.  
The barrier can be equipped and personalized with below mentioned accessories.

## ACCESSORIES



**C24**  
24v battery charger control board.



**D24**  
Control board for Daphne barriers.



**DA019**  
3Ah battery fixing kit for Daphne 6m and 3m fast.



**DA021**  
Single channel loop detector.



**DA011**  
Fixed support for boom adjustable height wise.



**AM001**  
Back-up battery (12Vdc - 3Ah).



**DA009**  
Reflecting strips (12 pcs).



**DA020**  
6m tubular telescopic boom.



**DA030**  
Calibrated spring for 6m tubular telescopic boom.



**DA017**  
Fixing plate for 6m tubular telescopic boom.



## KITS

---

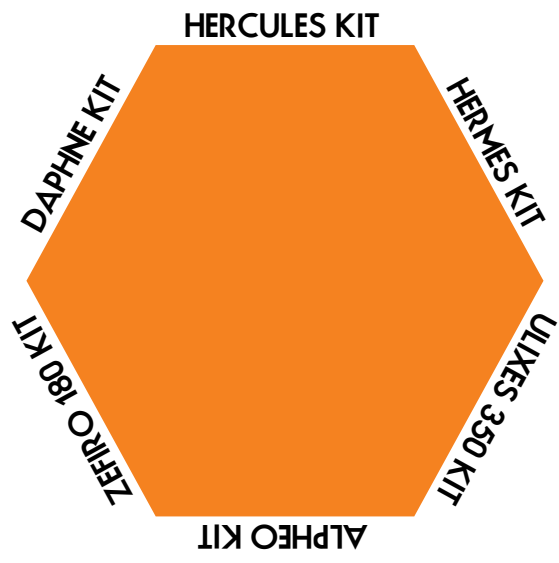

# HERCULES KIT



**SH5002302100**  
**SH500241000**  
 Sliding gearmotor Hercules in 230Vac or 24Vdc, complete with foundation plate and control board with receiver.



**AV223**  
 Venus two-channel rolling code transmitter.



**AFAP20**  
 Pair of wall-type photocells Argo 20m.



**APGL**  
 Pegasus led flashing light with base and built-in antenna in 220Vac and 24Vdc versions.



**ASM1S**  
 Wall-type key-pad die-cast aluminium.



**ACRAD-S**  
 Pair of vertical switch limit.

230V

24V

230V

24V

|                  | SH5002302100 | SH500241000 | AV223 | AFAP20 | APGL | ASM1S | ACRAD-S |
|------------------|--------------|-------------|-------|--------|------|-------|---------|
| <b>HER001L</b>   | ●            |             | ● ●   | ●      | ●    | ●     | ●       |
| <b>HER020L</b>   |              | ●           | ● ●   | ●      | ●    | ●     | ●       |
| <b>HER001-FL</b> | ●            |             | ●     | ●      | ●    |       | ●       |
| <b>HER020-FL</b> |              | ●           | ●     | ●      | ●    |       | ●       |

# HERMES KIT

**HEM001**  
 Pair of Hermes 200 electromechanical gear motors (right-hand side and left-hand side) 24Vdc with encoder and fixing brackets, complete of control board (A24ASC31).



**HEM002**  
 Pair of Hermes 250 electromechanical gear motors (right-hand side and left-hand side) 24Vdc with encoder and fixing brackets, complete of control board (A24ASC31).



**AV223**  
 Venus two-channel rolling code transmitter.



**AFEP**  
 Pair of wall-type photocells Elettra.



**APG24G**  
 Pegasus flashing light with base and built-in antenna in 24Vdc version.

24V  
 24V

|        | HEM001 | HEM002 | AV223 | AFEP | APG24G | A24ASC31 |
|--------|--------|--------|-------|------|--------|----------|
| HEM200 | ●      |        | ●     | ●    | ●      | ●        |
| HEM250 |        | ●      | ●     | ●    | ●      | ●        |



# ULIXES 350 KIT

**BU352302002**  
**BU350242002**  
Pair of Ulixes 350 swing gates operators, in 230Vac or 24Vdc versions, complete with fixing brackets.



**U230ASC31**  
**A24ASC31**  
Control board with built-in receiver in ABS box (18x21), in 230Vac and 24Vdc versions.



**AV223**  
Venus two-channel rolling code transmitter.



**AFAP20**  
Pair of wall-type photocells Argo 20m.



**APGL**  
Pegasus led flashing light with base and built-in antenna in 220Vac and 24Vdc versions.



**ASM15**  
Wall-type key-pad die-cast aluminium.

230V

24V

230V

24V

|           | BU352302002 | BU350242002 | U230ASC31 | A24ASC31 | AV223 | AFAP20 | APGL | ASM15 |
|-----------|-------------|-------------|-----------|----------|-------|--------|------|-------|
| ULI001L   | ● ●         |             | ●         |          | ● ●   | ●      | ●    | ●     |
| ULI020L   |             | ● ●         |           | ●        | ● ●   | ●      | ●    | ●     |
| ULI001-FL | ● ●         |             | ●         |          | ●     | ●      | ●    |       |
| ULI020-FL |             | ● ●         |           | ●        | ●     | ●      | ●    |       |







# ALPHEO KIT

**BA232302100+BA232300000**  
**BA230241000+BA230240000**  
 Pair of Alpheo swing gate operator in 230Vac or 24Vdc versions, complete with control board, built-in receiver and articulated arms with fixing brackets.



**ASM15**  
 Wall-type key-pad die-cast aluminium.



**AV223**  
 Venus two-channel rolling code transmitter.



**AFAP20**  
 Pair of wall-type photocells Argo 20m.



**APGL**  
 Pegasus led flashing light with base and built-in antenna in 220Vac and 24Vdc versions.

|      | BA23202100<br>BA232300000 | BA23241000<br>BA230240000 | AV223 | AFAP20 | APGL | ASM15 |
|------|---------------------------|---------------------------|-------|--------|------|-------|
| 230V | ● ●                       |                           | ● ●   | ●      | ●    | ●     |
| 24V  |                           | ● ●                       | ● ●   | ●      | ●    | ●     |
| 230V | ● ●                       |                           | ●     | ●      | ●    |       |
| 24V  |                           | ● ●                       | ●     | ●      | ●    |       |



# ZEFIRO 180 KIT



**BN182300000**  
**BN180240000**  
Pair of Zefiro 180 swing gates operators, in 230Vac or 24Vdc versions, complete with fixing brackets.



**U230ASC31**  
**A24ASC31**  
Control board with built-in receiver in ABS box (18x21), in 230Vac and 24Vdc versions.



**AV223**  
Venus two-channel rolling code transmitter.



**AFAP20**  
Pair of wall-type photocells Argo 20m.



**APGL**  
Pegasus led flashing light with base and built-in antenna in 220Vac and 24Vdc versions.



**ASM15**  
Wall-type key-pad die-cast aluminium.

230V

24V

230V

24V

|           | BN182300000 | BN180240000 | U230ASC31 | A24ASC31 | AV223 | AFAP20 | APGL | ASM15 |
|-----------|-------------|-------------|-----------|----------|-------|--------|------|-------|
| ZEF001L   | ● ●         |             | ●         |          | ● ●   | ●      | ●    | ●     |
| ZEF020L   |             | ● ●         |           | ●        | ● ●   | ●      | ●    | ●     |
| ZEF001-FL | ● ●         |             | ●         |          | ●     | ●      | ●    |       |
| ZEF020-FL |             | ● ●         |           | ●        | ●     | ●      | ●    |       |



# DAPHNE 3M FAST KIT



### DA60242000

Daphne barrier body with built-in flashing light in 3m-fast boom versions, complete with foundation plate and control board with built-in receiver.



### DA014+DA004+DA023+DA029

Kit made of boom, joint and calibrated spring in 3m-fast (rectangular) versions.



### DA009

Reflecting strips.



### AFAP20

Pair of wall-type photocells Argo 20m.



### AV223

Venus two-channel rolling code transmitter.



### DALED3RV

Red and green LED kit for 3M booms.

### DALED3R

Red LED kit for 3M booms.

|                        |            |             |       |             |       |        |
|------------------------|------------|-------------|-------|-------------|-------|--------|
|                        | DA60242000 | DA004+DA023 | DA009 | DA014+DA029 | AV223 | AFAP20 |
| DAP005<br>3m fast boom | ●          | ●           | ●     | ●           | ●     | ●      |

# DAPHNE 4M KIT



**DA009**  
Reflecting strips.



**DA026**  
Red anti-choc protection rubber, complete with caps for 4m booms.



**DA0241000**  
Daphne barrier body with built-in flashing light for 4m boom, complete with foundation plate and control board with built-in receiver.



**DA005+DA007+DA029**  
**DA006+DA008+DA024**  
Kit of boom joint and calibrated spring in circular or rectangular 4m boom versions.



**AV223**  
Venus two-channel rolling code transmitter.



**AFAP20**  
Pair of wall-type photocells Argo 20m.



**DALED4RV**  
Red and green LED kit for 4M booms.  
**DALED4R**  
Red LED kit for 4M booms.

|        | DA0241000 | DA005+DA007+DA029 | DA006+DA008+DA024 | DA009 | DA026 | AV223 | AFAP20 |
|--------|-----------|-------------------|-------------------|-------|-------|-------|--------|
| DAP008 | ●         | ●                 |                   | ●     |       | ●     |        |
| DAP003 | ●         |                   | ●                 | ●     | ●     | ●     | ●      |

# DAPHNE 6M KIT



### DA60241000

Daphne barrier body with built-in flashing light in 6m, complete with foundation plate and control board with built-in receiver.



### DA020+DA017+DA030

Kit made of boom, joint and calibrated spring in 6m (telescopic).



### DA009

Reflecting strips.



### AV223

Venus two-channel rolling code transmitter.



### DA011

Fixed support for booms, adjustable height wise.

|                              |            |                   |       |       |       |
|------------------------------|------------|-------------------|-------|-------|-------|
|                              | DA60241000 | DA020+DA017+DA030 | DA009 | DA011 | AV223 |
| DAPB05<br>6m telescopic boom | ●          | ●                 | ●     | ●     | ●     |



## ACCESSORIES

---

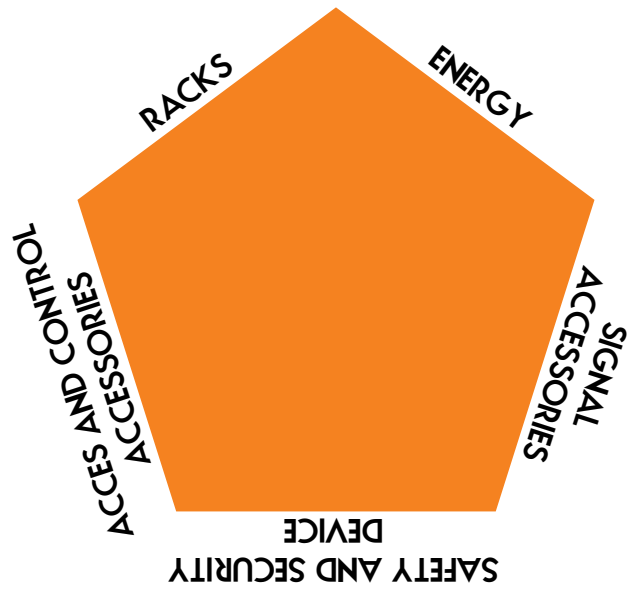

# ENERGY RECEIVER



## ENERGY FUNCTIONS

- 433Mhz two-channels receiver
- Crepuscular functions (light sensor)
- Energy saving (system stand-by)
- Garden lights or others applications
  
- Available on demand in 868Mhz

Energy multifunction receiver is made only with high quality materials for a reliability and unequalled life.

The receiver can work with fixed or rolling codes, working with the first registered transmitter and can be programmed with four different working modalities.

### **RXE230**

Energy 230Vac receiver in waterproof box with energy save function and the possibility to work with fixed or rolling codes.

### **RXE24**

Energy 24Vdc receiver in waterproof box with energy save function and the possibility to work with fixed or rolling codes.

### **AAN43325**

Altea 433Mhz tuned antenna with 2,5m cable.

### **AAN43365**

Altea 433Mhz tuned antenna with 6,5m cable.





# SIGNAL ACCESSORIES

## PEGASUS FLASHING LIGHT

### APG24G

Pegasus 24Vdc flashing light with electronics, grey base and yellow cap.

### APG220G

Pegasus 230Vac flashing light with electronics, grey base and yellow cap.

### APGL

Pegasus 24/230V flashing light with electronics, built-in antenna and LED card. Grey base and yellow cap.



## PEGASUS ACCESSORIES

### KAFPG

Grey wall fixing support, complete with screws and gaskets.

### AAN433P

Antenna 433MHz, for Pegasus flashing light series. To be used with KAFPG accessory.



## ALA FLASHING LIGHT

### ALA2E220G

Ala flashing light, mod. 2, with lamp, 230Vac electronic and yellow cap.

### ALA2E24G

Ala flashing light, mod. 2, with lamp, 24Vdc electronic and yellow cap.

### ALA2SL220G

Ala flashing light, mod. 2, without electronics, 230Vac and yellow cap.

### ALA2SL24G

Ala flashing light, mod. 2, without electronics, 24Vdc and yellow cap.



## ALEDINO LAMPS

Stagnoli LED lamp, to grant higher brightness saving energy and in full respect with European regulations. ALEDino lamps come from a long and detailed research by Stagnoli R&D department. Now Stagnoli can introduce one of its main innovations.

**These lamps grant a sensible energetic save thanks to LED lower consumption and they are completely in respect with European regulations 2005/32/CE, art. 3/2, valid starting 01.09.2010.**

All aLEDino lamps are provided with traditional Edison 14 joint, which allows the use and replacement with traditional systems.



### ALLED

12/24/230 Vac-dc LED lamp with EDISON 14 joint.

### AL1427

Adapter for joint from E14 to E27



# SIGNAL ACCESSORIES

APOLLO 24V AND 230V TRAFFIC LIGHTS WITH LEDS AND ALUMINIUM BODY



**ASF50L1RV**  
One body Twin colour (red and green) traffic light with 50 LED card, 24Vdc .  
**ASF50L1RV230**  
One body Twin colour (red and green) traffic light with 50 LED card, 230Vdc .



**ASF25L2RV230D**  
Traffic light with double lamp and arrows (230Vac)

**ASF25L2RVD**  
Traffic light with double lamp and arrows (24V)



**AMPS**  
Pair of brackets for traffic light post fixing.



**APS**  
Galvanized post (ø 60mm) for traffic light. 3m length.



**AA016**  
Battery charger kit for 24Vdc motor.  
Suitable for control board.

# SIGNAL ACCESSORIES

## Apollo 230Vac traffic lights with LEDs

### ASF25L1G230

Apollo traffic light single yellow lamp 230Vac with LED card. ø lens 120mm.

### ASF25L1R230

Apollo traffic light single red lamp 230Vac with LED card. ø lens 120mm.

### ASF25L1V230

Apollo traffic light single green lamp 230Vac with LED card. ø lens 120mm.

### ASF25L2RV230

Apollo traffic light double red-green lamp 230Vac with LED card. ø lens 120mm.

### ASF25L3GRV230

Apollo traffic light triple yellow-red-green lamp 230Vac with LED card. ø lens 120mm.

## Apollo 24V traffic lights with LEDs

### ASF25L1G

Apollo traffic light single yellow lamp 24Vdc with LED card. ø lens 120mm.

### ASF25L1R

Apollo traffic light single red lamp 24Vdc with LED card. ø lens 120mm.

### ASF25L1V

Apollo traffic light single green lamp 24Vdc with LED card. ø lens 120mm.

### ASF25L2RV

Apollo traffic light double red-green lamp 24Vdc with LED card. ø lens 120mm.

### ASF25L3GRV

Apollo traffic light triple yellow-red-green lamp 24Vdc with LED card. ø lens 120mm.

## Apollo 230V traffic lights with light-bulb

### ASF1G

Apollo traffic light single yellow light-bulb. ø lens 120mm.

### ASF1R

Apollo traffic light single red light-bulb. ø lens 120mm.

### ASF1V

Apollo traffic light single green light-bulb. ø lens 120mm.

### ASF2RV

Apollo traffic light double red-green light-bulb. ø lens 120mm.

### ASF3GRV

Apollo traffic light triple red-green-yellow light-bulb. ø lens 120mm.

# SIGNAL ACCESSORIES

## APOLLO PLAST



Apollo plast is the traffic light with Nylon glass-fibre body, to make it light and suitable for installation in suspended structures.

The traffic light is modular, so you can rig up the lights as you like, and has the possibility to fit both the 18 LED cards or 45 LED lamp.

Apollo plast traffic lights respects European law 2005/32/CE article 3/2.

All models are available in 230Vac and 24Vdc versions with lens  $\varnothing$  120mm.

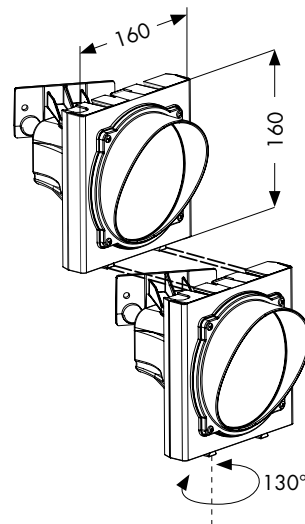
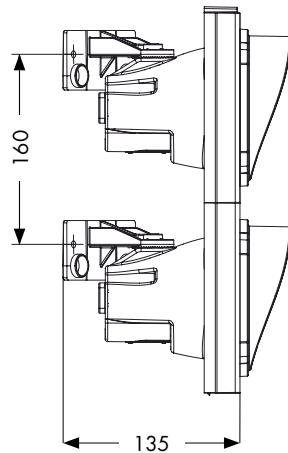

### Traffic light with 24Vdc LED card

#### ASFR

Complete traffic light with 24Vdc red LED card.  $\varnothing$  lens 120mm.

#### ASFG

Complete traffic light with 24Vdc yellow LED card.  $\varnothing$  lens 120mm.

#### ASFV

Complete traffic light with 24Vdc green LED card.  $\varnothing$  lens 120mm.

# SIGNAL ACCESSORIES

## Apollo plast twin

### ASF36L1RV

Twin colour one lens traffic light with 36 LED card, 24V to manage red and green colours.

### ASF36L1RV230

Twin colour one lens traffic light with 36 LED card, 230V to manage red and green colours.



## Traffic lights suitable for E27 45LED lamp

### ASFRL

Apollo plast with red lens, Nylon body in glass-fibre.  $\varnothing$  lens 120mm.

### ASFGL

Apollo plast with yellow lens, Nylon body in glass-fibre.  $\varnothing$  lens 120mm.

### ASFVL

Apollo plast with green lens, Nylon body in glass-fibre.  $\varnothing$  lens 120mm.

### ASFK230

Conversion Kit to allow the use of Apollo plast from 24Vdc to 230Vac.

## CONTROL BOARDS

### ACNSEM3L230

230Vac supplied control board for double or triple light traffic lights.



### ACNSEM3L

24Vdc supplied control board for double or triple light traffic lights.



### AKLS

24Vdc supplied control board for intermittence of the traffic lights.



# SAFETY AND SECURITY DEVICES

## PHOTOCELLS AND ACCESSORIES



### AFAP20

Pair of wall-type Argo photocells. 180° horizontal and 10° vertical direction angle, 12-24Vdc power supply and max range 20m.



### AFEP

Pair of wall-type Elettra photocells. 12/24Vdc power supply and max range 15m.



### AFAPC

Inox cover for ARGO AFAP20



### ACA500

Pair of Atlas 500mm column supports for Elettra or Argo series.

### ACA1000

Single Atlas 1000mm column support for double photocell or photocell and key-pad.

### ACA500S

Single Atlas 500mm column support for Elettra or Argo series.



### ACA7

Base plate for ACA100 and ACA500.

## COLUMNS FOR PHOTOCELLS AND KEYPADS



### ASJD

Janus digital key-pad for Atlas column. Complete with decoder.



### ASJC1

Janus key-pad for Atlas column. One micro and European cylinder single key.



### ASJC2

Janus key-pad for Atlas column. Two micro and European cylinder single key.

# SAFETY AND SECURITY DEVICES

## ACCESSORIES

**ACA1**  
Hera external security safe.



**ACA4**  
Double-function button.



**ACA5**  
Mechanical wall-type release.



**ACA6**  
Embedding-type box for mechanical wire release and three buttons.



## SENSORS

**PRAP**  
Microwave detector for automatic gates or industrial doors, with reading in the both senses of functioning.



**DA021**  
Single channel loop detector.



## SAFETY EDGE

**AC100E200**  
Pressure sensor

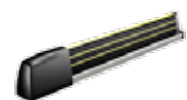

**AC000**  
Wi-fi transmitter and receiver



## ELECTROLOCKS

**AU002A**  
12V vertical electrolock



**AU005** - 12V horizontal right-hand side electrolock  
**AU006** - 12V horizontal left-hand side electrolock



# ACCESS AND CONTROL ACCESSORIES

---



## **AV223**

Venus two-channels, 433Mhz rolling code self-learning transmitter.

## **AZ442**

Zeus four clonable channels 433Mhz, fixed code, transmitter.



## **AK443**

Kallisto four-channels, 433Mhz, rolling code self-learning transmitter.



# ACCESS AND CONTROL ACCESSORIES

## WALL-TYPE KEY-PADS

### ASM1S

Wall-type key-pad in die-cast aluminium with DIN-European cylinder and individual key- 1 function.

### ASM2S

Wall-type key-pad in die-cast aluminium with DIN-European cylinder and individual key- 2 functions.

### ASMTAS

Wall-type two-channels key-pad with four digit. Complete with decoder.



## EMBEDDING-TYPE KEY-PADS

### ASIP1S

Embedding -type key-pad in die-cast aluminium with DIN-European cylinder and individual key- 1 function.

### ASIP2S

Embedding -type key-pad in die-cast aluminium with DIN-European cylinder and individual key- 2 functions.

### ASIPTAS

Embedding-type two channels key-pad with four digits. Complete with decoder.



## ELECTRIC BOXES

### ASC8

Electric box 13x16 in ABS (144 units lot or multiple. Price for single product).

### ASC25

Electric box 15x20 in ABS (60 units lot or multiple. Price for single product).

### ASC30

Electric box 35x25 in ABS (18 units lot or multiple. Price for single product).

### ASC31

Electric box 18x23 in ABS (46 units lot or multiple. Price for single product).



## PUSH-BUTTONS

### APU1M

Single function push-button.

### APU2M

Double function push-button.

### APU2MS

Double function push-button with stop.





# RACKS

## STEEL RACKS

|   |
|---|
| <b>ACRM1 2000</b><br>M4 22x22x2000mm galvanized steel rack. Max 4000Kg.                                     |
| <b>ACRM3 2000</b><br>M4 30x12x2000mm galvanized steel rack complete with accessories.                       |
| <b>ACRM1</b><br>M4 22x22x1000mm galvanized steel rack. Max 4000Kg.  |
| <b>ACRM2</b><br>M4 30x8x1000mm galvanized steel rack complete with accessories.<br>Max 1200Kg.              |
| <b>ACRM3</b><br>M4 30x12x1000mm galvanized steel rack complete with accessories.<br>Max 2200Kg. 4m package. |
| <b>ACRM4</b><br>M4 22x22x1000 not galvanized steel rack. Max 4000Kg.  |
| <b>ACRM6</b><br>M6 30x30x1000mm galvanized steel rack. Max 4000Kg.  |

| HERCULES | ACHILLES 1200 | ACHILLES 2200 | ACHILLES 4000 |
|----------|---------------|---------------|---------------|
|          |               | ●             | ●             |
|          |               | ●             | ●             |
| ●        | ●             |               |               |
| ●        | ●             |               |               |
| ●        | ●             | ●             |               |
| ●        | ●             | ●             | ●             |
|          |               |               | ●             |

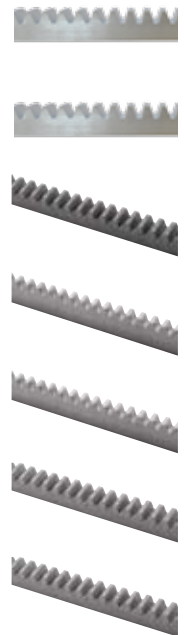

## ACCESSORIES

|   |
|---|
| <b>ACRVA</b><br>6,3X25 self-drilling screw for rack fixing                            |
| <b>SP350</b><br>Washer in AISI 430 stainless steel for rack fixing                    |
| <b>ACRFF</b><br>Pair of iron limit switch cams.                                       |
| <b>ACRAD-S</b><br>Pair of vertical limit switch cams for ACRV6 rack.                  |
| <b>ACRR</b><br>Washers for rack fixing  |
| <b>ACRVP333</b><br>6,3X38 self-drilling screw for ACRV33 rack                         |
| <b>ACRSCUN</b><br>Pair of universal switch limit cams (to be used with ACRS20Z rack). |
| <b>ACRCFCVV4</b><br>Pair of limit switch cams for ACRV4 rack.                         |
| <b>ACRCFCV</b><br>Pair of vertical limit switch cams.                                 |



## OTHER INFORMATIONS

### CONTROL BOARD CHARACTERISTICS

| A24 | AA2041 | I24 | U230 | E24 | SA4041 | H24 | H230 |                                     |
|-----|--------|-----|------|-----|--------|-----|------|-------------------------------------|
| •   | •      | •   | •    | •   | •      | •   | •    | Automatic closing                   |
| •   |        | •   | •    | •   | •      | •   | •    | Impulse locking in opening          |
|     |        | •   | •    | •   |        | •   | •    | Impulse locking in pause            |
|     |        | •   | •    | •   |        | •   | •    | Fast lock                           |
| •   | •      | •   | •    | •   | •      | •   | •    | Open - close or open - stop - close |
| •   | •      | •   | •    | •   | •      | •   | •    | Pre-flashing                        |
|     |        |     | •    | •   |        | •   | •    | Suction cap lock                    |
| •   |        |     | •    | •   |        |     |      | Hammering stroke                    |
| •   |        | •   | •    | •   |        | •   | •    | Energy saving                       |
| •   |        |     | •    | •   |        |     |      | Single or double motor movement     |
| •   |        | •   |      | •   |        | •   |      | Setting with encoder                |
| •   |        | •   | •    | •   | •      | •   | •    | Soft start selection                |
| •   |        |     | •    | •   | •      | •   | •    | Open - close                        |
| •   |        | •   |      | •   |        | •   |      | Total obstacle inversion            |
| •   | •      | •   | •    | •   | •      | •   | •    | Pause time programming              |
| •   |        |     | •    | •   |        |     |      | Leaf displacement in opening        |
| •   |        |     | •    | •   |        |     |      | Leaf displacement in closing        |
| •   |        | •   | •    | •   | •      | •   | •    | Slowdown                            |
| •   |        | •   | •    | •   | •      | •   | •    | Electronic force control            |
|     |        |     | •    | •   |        | •   | •    | Open gate warning light             |
| •   |        | •   | •    | •   | •      | •   | •    | Output fixed flashing light         |
|     | •      |     |      |     | •      |     |      | Output intermittent flashing light  |
| •   | •      | •   |      |     |        |     |      | Courtesy light exit                 |
| •   |        |     | •    | •   | •      |     |      | Electrolock output 12Vdc            |
|     | •      |     |      |     |        |     |      | Auxiliary output 12Vdc              |
| •   |        | •   | •    | •   |        | •   | •    | Auxiliary output 24Vac              |
|     | •      |     |      |     | •      |     |      | Auxiliary output 24Vdc              |
|     |        |     |      |     |        |     |      | Output second radio channel         |
|     |        |     | •    |     |        |     | •    | Output N.O. off tension             |
| •   |        | •   | •    | •   | •      | •   | •    | Input diagnosis on display          |
|     |        |     |      |     |        |     |      | LED input diagnosis                 |
| •   | •      | •   | •    | •   | •      | •   | •    | Input antenna                       |
| •   | •      | •   | •    | •   | •      | •   | •    | Start function                      |
| •   |        |     | •    | •   | •      | •   | •    | Pedestrian function                 |
| •   |        | •   | •    | •   | •      | •   | •    | Stop input                          |
|     |        |     |      |     |        |     |      | Input open photocell                |
| •   | •      | •   | •    | •   |        | •   | •    | Input close photocell               |
| •   |        |     | •    | •   | •      | •   | •    | Input close and open photocell      |
| •   |        |     |      |     | •      | •   | •    | Limit switch input                  |
|     |        |     | •    | •   | •      | •   | •    | Input edge                          |
| •   | •      |     |      |     |        |     |      | Built-in fixed code receiver        |
| •   |        | •   | •    | •   |        | •   | •    | Built-in rolling code receiver      |
|     |        |     |      |     |        |     |      | Molex plug-in receiver connector    |
| •   |        |     |      |     |        | •   | •    | Magnetic limit switch               |
|     |        |     |      |     |        |     |      | Built-in battery charger            |
| •   |        | •   |      | •   |        | •   |      | Optional battery charger            |

## GENERAL CONDITIONS OF SALE

Both Parties agree that all sales of products (hereinafter "Products") made by Stagnoli TG S.r.l., with headquarters in Desenzano d/G, Via Ticino 14 (hereinafter "Stagnoli") to customers (hereinafter the "Customer") are regulated by these General Conditions, being an integrating part of the contract existing between the parties and replacing any other different clause contained in previous agreements, in the order (hereinafter "the Order") or in any other document coming from the Customer.

### 1) Order and Order Confirmation

Stagnoli reserves the right to accept, refuse or modify, wholly or partially, the Customer's Order, according to availability of stock and current production capacity, in conformity with these General Conditions.

Should Stagnoli modify the Order made by the Customer, the modified Order shall have the value of a new offer and must be accepted in writing by the Customer, also by fax, otherwise the Order will be cancelled. It remains agreed that, in any case, the lack of an explicit Order Confirmation from Stagnoli (hereinafter, the "Order Confirmation") shall not be considered as a tacit acceptance of said Order.

In compliance with these General Conditions, Orders may not be, under any circumstances or in any way, cancelled or modified, either wholly or partially by the Customer once Stagnoli has dispatched the Order Confirmation unless otherwise agreed between the Parties.

Should the order be cancelled, wholly or partially, after Stagnoli has dispatched the Order Confirmation, as in the case that the Customer refuses to collect the ordered goods, Stagnoli shall have the right to obtain payment from the Customer of the full price of the ordered goods, as well as a right to major damages.

### 2) Prices

Stagnoli sells and the Customer buys at the prices indicated in the Stagnoli Price List (hereinafter the "Price List"), always intended ex works and exclusive of VAT (hereinafter the "Price" or the "Prices").

The Customer shall pay the List Prices in force on the date of each delivery of Products to the Customer. Each new Stagnoli Price List cancels and replace all those previous, as from the date on which it is adopted.

The Customer undertakes to accept, unconditionally, all changes to the Price List made between the date of each Order and the date of the relative delivery.

### 3) Conditions of Payment

Unless otherwise agreed in writing by the Parties, the Price shall be paid according to the terms and conditions stated in the Stagnoli invoice. In absence of such indication in the invoice or different written agreement between the Parties, payments are to be made within 30 (thirty) days from the end of the month of the issue of the invoice relative to the sold Products. Payments are to be made by means of bank transfer or bank remittance.

Lack of payment of the Price within the expiry of the single invoice shall automatically generate passive interest, without the need of any communication or the placing in the fault of the Customer by Stagnoli. Said interest shall be applied from the day after the expiry of the single invoice and until the date of the effective payment, and shall be calculated on the basis of law D. Lgs. 231/2002. In these cases, further to interest, Stagnoli shall have right to the integral reimbursement of costs borne to recover any sums not punctually received, save, in any case, the refunding of major damages.

Notwithstanding the above, in the case of split-delivery Orders, should the Customer delay payment, even for one delivery or a part of it, with respect to the forecast expiry, Stagnoli shall have the right to suspend further deliveries until the whole outstanding sum has been paid, without prejudice to the right to cancel the contract in compliance with the following art. 12.

### 4) Terms of delivery

Delivery terms of Products are those indicated in Stagnoli's Order Confirmation.

The Products are sold ex works, from the factory of Stagnoli TG S.r.l. or a secondary branch which will be indicated to the customer each time. Stagnoli fulfils the obligation to deliver the Products by consigning the same to the carrier. Stagnoli shall be considered free of this obligation in all cases where consignment to the carrier has become impossible or exceedingly expensive, due to major force or unforeseen circumstances such as, purely for example, strikes, impossibility to procure raw materials, wars or terrorist attacks, massacres meteorological events or any other event outside Stagnoli's control. The Parties expressly agree that a simple delay in delivering the Products does not attribute any right to the Customer to request cancellation of the contract or to refuse collection of the Products, or not to pay the relative Price. On his side, the Customer undertakes to do all the necessary to collect the goods once they are available. For any delays on the Customer's part in collecting the goods Stagnoli shall have the right, further to payment of the Price, to payment of costs connected with the storage of the goods in Stagnoli warehouses, third-party warehouses, or those of the carrier, save, in any case, the right to refunding of any damages.

Furthermore, if the Products are collected late, the Customer personally assumes all risks for any damage deriving from storage of the goods, be it in Stagnoli warehouses, those of appointed third parties, or the carrier.

### 5) Deliveries

Unless otherwise agree in writing, Stagnoli, in the name and on behalf of the Customer, will name a trusted carrier or a carrier indicated by the Customer to deliver the Products, and the cost will be included each time in the invoice to the Customer. In any case, should the Product be stolen, lost or damaged, even partially, during transport and the events not directly caused by Stagnoli, the Customer shall be liable to pay the whole Price to Stagnoli, save the right to take action against the carrier and /or the third party resulting to be responsible. Save the responsibilities of the appointed carrier, all risks linked with the transport of the Products from the Stagnoli factory to the Customer's address or the place indicated by the Customer for delivery shall remain entirely to the Customer's charge.

Unless otherwise agreed between the Customer and Stagnoli, deliveries are not covered by any insurance policy other than the policy eventually stipulated by the carrier.

### 6) Warranties

6.1 Stagnoli guarantees that the Products in the Price List have been accurately manufactured, tested and inspected. Furthermore, Stagnoli supplies the Customer with a warranty for the Products against manufacturing faults for a period of 24 (twenty-four) months from the date of delivering the Products. Warranty will be granted to the final user and will be exclusively managed from the seller of the Product in compliance with Consumer Code and Art. 190 and ss Civ. Code.

The period of the warranty shall be extended to 36 (thirty-six) months in case the Customer-seller agreed to the Stagnoli training program. The warranty will be honoured by Stagnoli after the presentation of a fiscally valid document (invoice) relative to the sale of the Products to the Customer and the relative transport document. The defect and/or malfunction must be reported by the Customer to Stagnoli in writing (also by fax) within a maximum limit of 60 (sixty) days from the date of its discovery, otherwise the warranty will not be valid. The figured defects must be immediately reported in the delivery moment, otherwise the warranty will not be valid.

6.2 By effect of the warranty, the seller must identify the defect and, where is possible, proceed with repair or the replacement of the faulty Products or components and the payment of the costs concerning the replacing (transport, replacement work)

6.3 When the detected non conformity is due to Stagnoli manufacturing process, the Customer-seller shall be allowed to the right of refunding against Stagnoli.

However, Stagnoli warranty will not be valid in cases of damage, malfunctions or faults deriving from the incorrect installation of the Products differing from the indications given in the appropriate instructions for installation, supplied each time with the Products, as well as the relative standards in force at the time of installation and the general safety rules applied to this sector.

Stagnoli declines equally all responsibility for the non-observance, by the Customer or other user of the Products, of the safety standards and good rules of practice for the use and maintenance of said Products.

It is agreed that the Stagnoli warranty shall not be valid in all cases in which the Products are not installed by qualified staff (who issue a suitable certificate) and in all cases in which the Products are installed and/or used with accessories, complementary automotive articles, non-original mechanical or electronic parts supplied by other parties.

Finally, it is expressly agreed that Stagnoli shall not be responsible toward the Customer or third parties for any indirect, accidental or consequent damage suffered by the latter, including, purely for example, loss of production, reduced profits, loss of concluded contracts, waiver of commercial opportunities.

### 7) Split-delivery sales

When deliveries of sold Products are split, as well as the case of Price paid by instalments, ownership of the goods is transferred to the Customer only after the Price, relative to the supplied Products, have been paid. It is agreed that, however, the Customer assumes all risks relative to the Products as from the time of delivery, even when the goods have already been delivered, in compliance with previous article 4.

### 8) Brands and industrial property

Stagnoli guarantees its ownership or, in any case, to fully and freely own the registered brands that distinguish the Product. All persons are therefore forbidden to remove, cancel, integrate, alter in any way or replace with others, the brands, marks and other distinguishing signs applied to the Products, to their components or on their packaging. Unless authorized in writing by Stagnoli, all persons are expressly forbidden to reproduce (wholly or partially) the brands and any other distinguishing marks owned by Stagnoli, nor may they use them in any other way for their own purposes or those of third parties.

The Customer and other third parties are forbidden to reproduce, copy or imitate in any way the Products patented by or on behalf of Stagnoli or protected by other rights of industrial or intellectual property in favour of Stagnoli.

### 9) Privacy

Both parties under take to apply all the measures necessary to adequately safeguard privacy of information received regarding or due to the supply of the Products.

### 10) Governing Law and Competent Court

These General Conditions and contractual terms for the sale of the Products are subject to Italian Law.

Any controversy arising with reference to the interpretation and application of the General Conditions, as well as the execution of supply governed by the same, shall be referred to the competent judge at the Court of Brescia.

### 11) Modification to General Conditions

Possible modifications of these General Conditions shall be effective unless previously agreed between the Parties in writing.

### 12) Resolutive Clause

In the case of non-fulfillment of the obligation to pay the Price as stated in previous articles 2 and 3, or in the absence of collection of the Products by the Customer, Stagnoli may send the defaulting Party notice to comply, by either registered mail or telefax.

After a fruitless period of 15 (fifteen) days from the date of notice without any effect, Stagnoli shall consider cancelled the contract regulated by the General Conditions.

In conformity with the Law, Stagnoli shall also have the right to request cancellation of the contract if the Customer is declared bankrupt or submitted to any other legal procedure and/or put into liquidation.

### 13) Final Clauses

The invalidity and/or the inefficiency of one or part of the clauses in these General Conditions do not render invalid or inefficient any of the others.

The partial or delayed exercise of any right, power or faculty foreseen in these General Conditions do not constitute the waiver of either Party with regard to the same.

The Customer

Having viewed and expressly accepted the clauses contained in articles 3) Payment; 4) Terms of delivery; 6) Warranties; 7) Split-delivery sales; 10) Governing Law and Competent Court; 12) Resolutive Clause; of these General Conditions of Sale, referred to articles 1341 and 1342 of Civil Code.

The Customer

H  
O  
W  
  
T  
O  
  
R  
E  
A  
C  
H  
  
U  
S

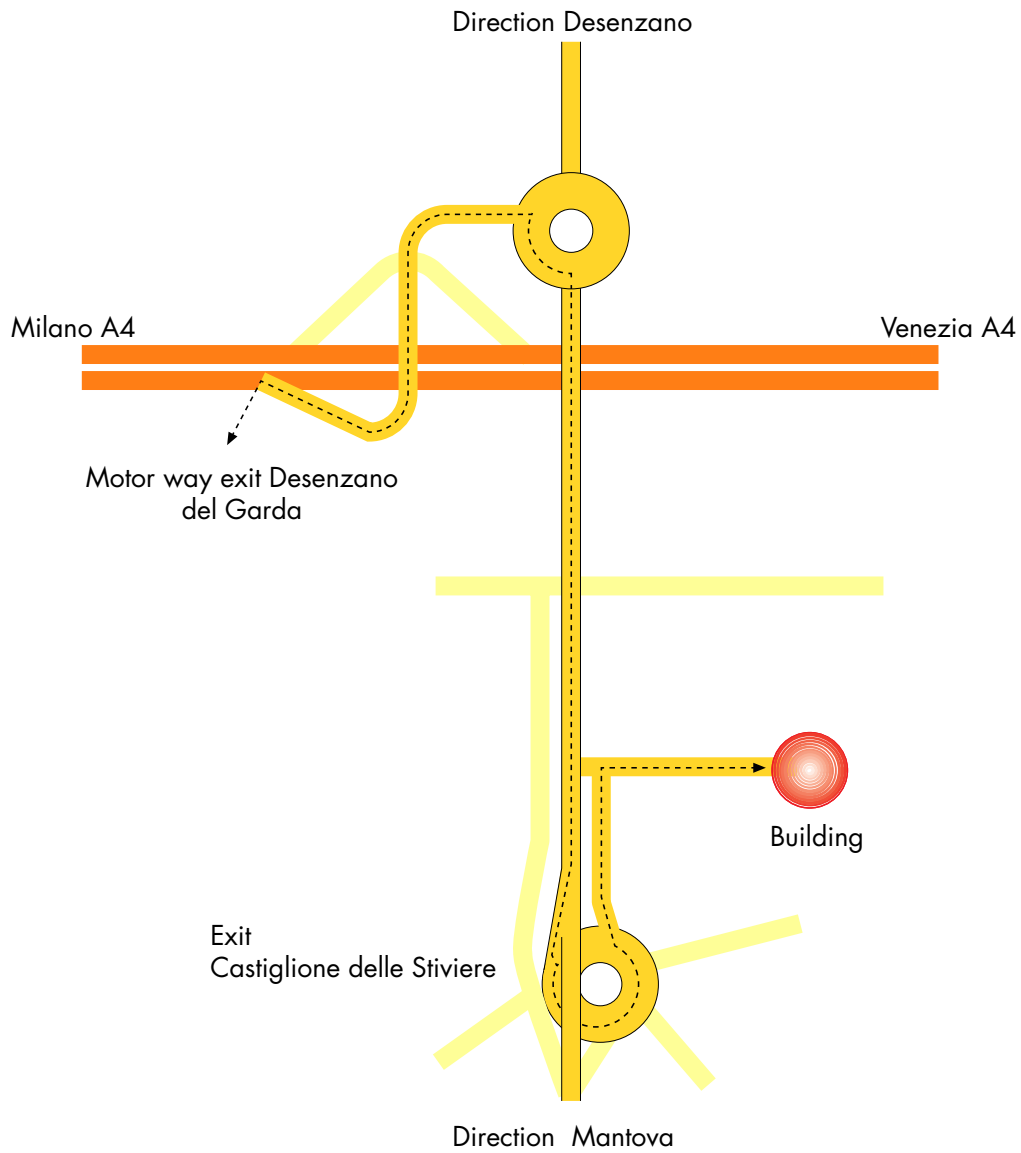

The information contained in this publication, including numerical data, has been prepared as a general guide to the products, but intending buyers and users must satisfy themselves as to the suitability and the safety of the products for their particular purposes and duties.

No responsibility is assumed for any errors herein.

The company reserves the right to alter the designs and material specifications of products shown in this publication without notice.



**STAGNOLI T.G. s.r.l.**

Via Mantova Traversa 1, 105 A/B

25017 Lonato (BS) Italy

Tel. (+39) 030.9139511

Fax (+39) 030.9139580

info@stagnoli.com

[www.stagnoli.com](http://www.stagnoli.com)